

SPEARHEAD

REACH MOWER RANGE



THE CUTTING PERFORMANCE YOU DESERVE

Spearhead has been at the forefront of vegetation control machinery for over three decades. We listen intently to customer feedback in a quest to perfect our machines. They're robust, long-lasting, and highly efficient.

Our Twiga range (Swahili for 'giraffe') has been part of the offering since 1995. Ensuring operator comfort, immense flexibility, and greater productivity, we hope you'll be as impressed as our partners are.

With Twiga, we set the standard for reach arm mowers. Anything less won't deliver the performance you deserve.

CONTENTS

TWIGA MINI SERIES	8	CONTROL SYSTEMS	28
TWIGA COMPACT SERIES	10	FLOAT SYSTEMS	30
TWIGA ECO SERIES	12	PRECISION CUTTING SYSTEMS	32
TWIGA CLASSIC SERIES	14	TEMPERATURE CONTROL SYSTEMS	34
TWIGA MID SERIES	16	DEBRIS CONTROL	34
TWIGA ORBITAL SERIES	18	QUICK ATTACHMENT SYSTEMS	35
TWIGA PRO SERIES	20	VISIBILITY SYSTEMS	35
TWIGA FLEX SERIES	22	SPECIALIST ATTACHMENTS	36
TWIGA CUSTOM BUILDS	24	SPECIFICATIONS	44
MOUNTING TYPES	26		
ARM TYPES	27		



WHY CHOOSE TWIGA?

You want to cut it faster, to the highest standard, and in the best possible comfort. We understand this, so every aspect of Twiga focuses on your needs.

Our customers vary from private estates with occasional cutting needs to high-output professional contractors with intense workloads.

That is why Twiga mowers attach to most tractors, with ample choice of arm and mounting types, to create your perfect cutting machine.

When it comes to reach, Twiga doesn't disappoint. Ranging from 2.6m to 8.9m, our powerful machines get your job done effectively and on time.

Countless Twiga features make your life easier. Autopilot, Autolevel, and Propilot are three major advances that give you incredible control and productivity. They make cab life more comfortable too, reducing operator pressure and fatigue.

Constructed from the ground up, every Twiga is a robust workhorse. Built for longevity, it will not let you down.

“ I looked at other machines, but I loved the build quality and technology of the Twiga. We've gained more work due to Twiga. Our output is 25% higher and it's helped us grow the business a good 30% to 40% in three years. ”

Will Clarke - Kent, UK

“ I can honestly say it's the best machine I've ever had. Given the amount of work it does in the cutting season, the Twiga is a massive asset to my business. And operationally, it's superior in many ways. ”

Gary Gilder - Lincolnshire, UK



SPECIFYING YOUR TWIGA

PICK YOUR POWER. FOR US IT'S RANGE DEFINING.

Our hedgecutter ranges are power linked.

TWIGA COMPACT	35HP
TWIGA ECO	60HP
TWIGA CLASSIC	65HP
TWIGA MID	75HP
TWIGA ORBITAL	85HP
TWIGA PRO	85HP
TWIGA FLEX	85HP

REACH. IT'S IN THE NAME.

The easiest and initial go-to when defining your requirements is often reach. The basic reach for all Spearhead Hedgecutters is in the naming convention.*

i.e. **TWIGA CLASSIC S60 = 6.0m**

TWIGA MID VFR55 = 5.5m



BASE UNIT DEFINED. NOW WHAT IS IT GOING ON?

Spearhead Reach Arms can be mounted to many different Prime Mover Vehicles.

CONSIDER...



TYPE, MODEL & MANUFACTURER



HORSEPOWER



HEIGHT & WEIGHT



LIFT CAPACITY

ARM TYPES. AS EASY AS ABC.

Spearhead offers a selection of different 'arm types' to provide additional functionality. The arm type for all Spearhead hedgecutters is also in the naming convention.

i.e. **TWIGA CLASSIC S60 = STANDARD**

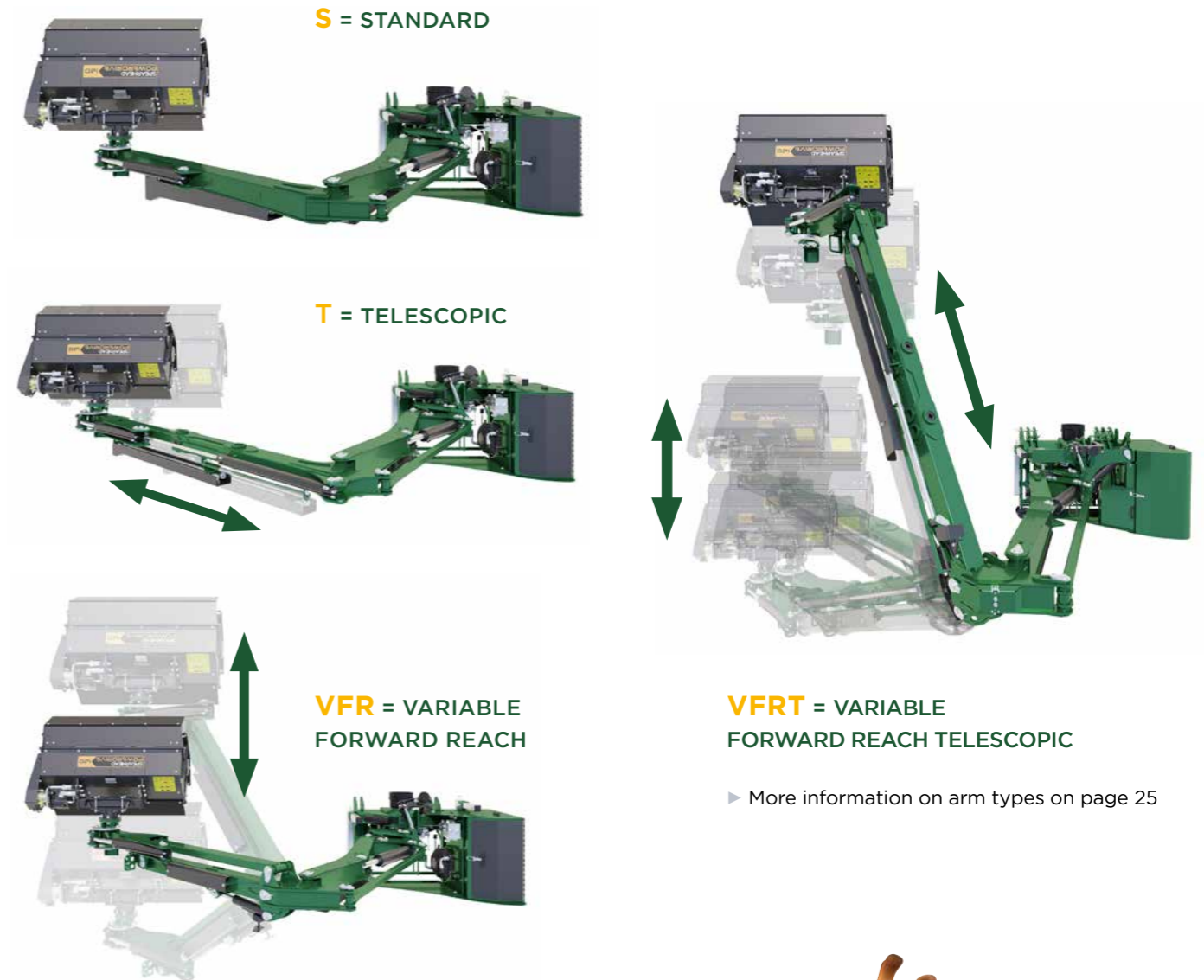

► More information on arm types on page 25

FUN FACT: TWIGA IS SWAHILI FOR GIRAFFE



TWIGA MINI SERIES



Ideal for amenity contractors, local authorities, and private estates Twiga Mini offers a lightweight arm for compact tractors.

Offering incredible value for money, the robust Twiga Mini punches above its weight. And with various reach options enjoy the versatility you need.

Achieve your perfect set-up and make light work of regular cutting. Mounted on the front or rear of your tractor, choose an arm reach up to 4.5 metres.

- ▶ Lightweight arm for compact tractors.
- ▶ Reach wide and high from front or rear mount.
- ▶ Select a VFR armset for additional comfort.

	MINIMUM WEIGHT GUIDE	MACHINE WEIGHT	MAXIMUM HORIZONTAL REACH	MAXIMUM VERTICAL REACH	MAXIMUM FORWARD REACH	TRANSPORT WIDTH	OIL FLOW REQUIREMENT
TWIGA MINI S26	500kg (1103lbs)	210kg (463lbs)*	2.60m (8' 5")	4.00m (13' 1")	—	1.00m (3' 4")	25-30 l/min
TWIGA MINI S37	900kg (1985lbs)	260kg (573lbs)*	3.70m (12' 1")	5.40m (17' 7")	—	1.30m (4' 4")	25-30 l/min
TWIGA MINI VFR37	1100kg (2426lbs)	310kg (684lbs)*	3.70m (12' 1")	5.40m (17' 7")	1.50m (4' 11")	1.30m (4' 4")	25-30 l/min



MAX REACH
3.70m
(12' 1")

TWIGA COMPACT SERIES

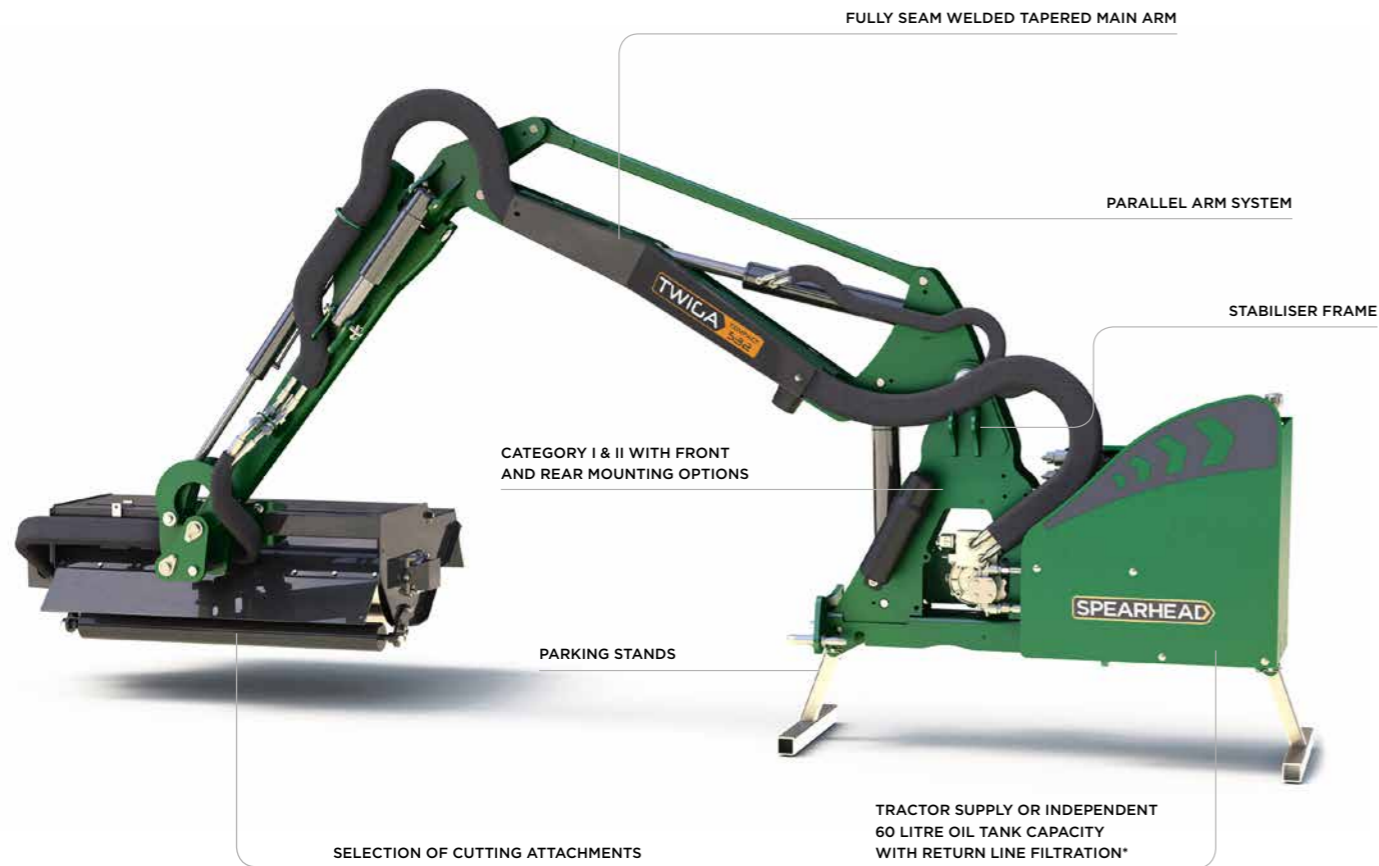





Whether you're a local authority, groundskeeper, or small agricultural site, enjoy a compact cutting arm with features and styling seen in larger models.

Watch your productivity soar as you reach up to 4.9 metres. Mount the arm where it works best for you and enjoy high visibility.

Use your Twiga Compact to complete more jobs. Choose from various attachments such as flail, saw and cutterbar.

- ▶ Professional features in a compact arm.
- ▶ Achieve the perfect set-up with flexible mounting positions.
- ▶ Get more done with additional cutting attachments.
- ▶ Specifications suited to your needs – Basic, Combi, Integrated, Front mount, Rear mount.

	 MINIMUM WEIGHT GUIDE	 MACHINE POWER	 MACHINE WEIGHT	 MAXIMUM REACH	 TRANSPORT WIDTH
TWIGA COMPACT S32	1500kg (3308lbs)	35hp	480kg (1058lbs)	3.20m (10' 5")	1.90m (6' 3")
TWIGA COMPACT S36	1500kg (3308lbs)	35hp	500kg (1103lbs)*	3.60m (11' 10")	1.90m (6' 3")
TWIGA COMPACT S42	1750kg (3859lbs)	35hp	520kg (1147lbs)	4.20m (13' 8")	2.30m (7' 6")
TWIGA COMPACT S46	1750kg (3859lbs)	35hp	540kg (1191lbs)*	4.60m (15' 1")	2.40m (7' 10")
TWIGA COMPACT S49	2000kg (4410lbs)	35hp	540kg (1191lbs)	4.90m (16' 1")	2.40m (7' 10")



MACHINE POWER
35hp



MAX REACH
4.90m (16' 1")

TWIGA ECO SERIES

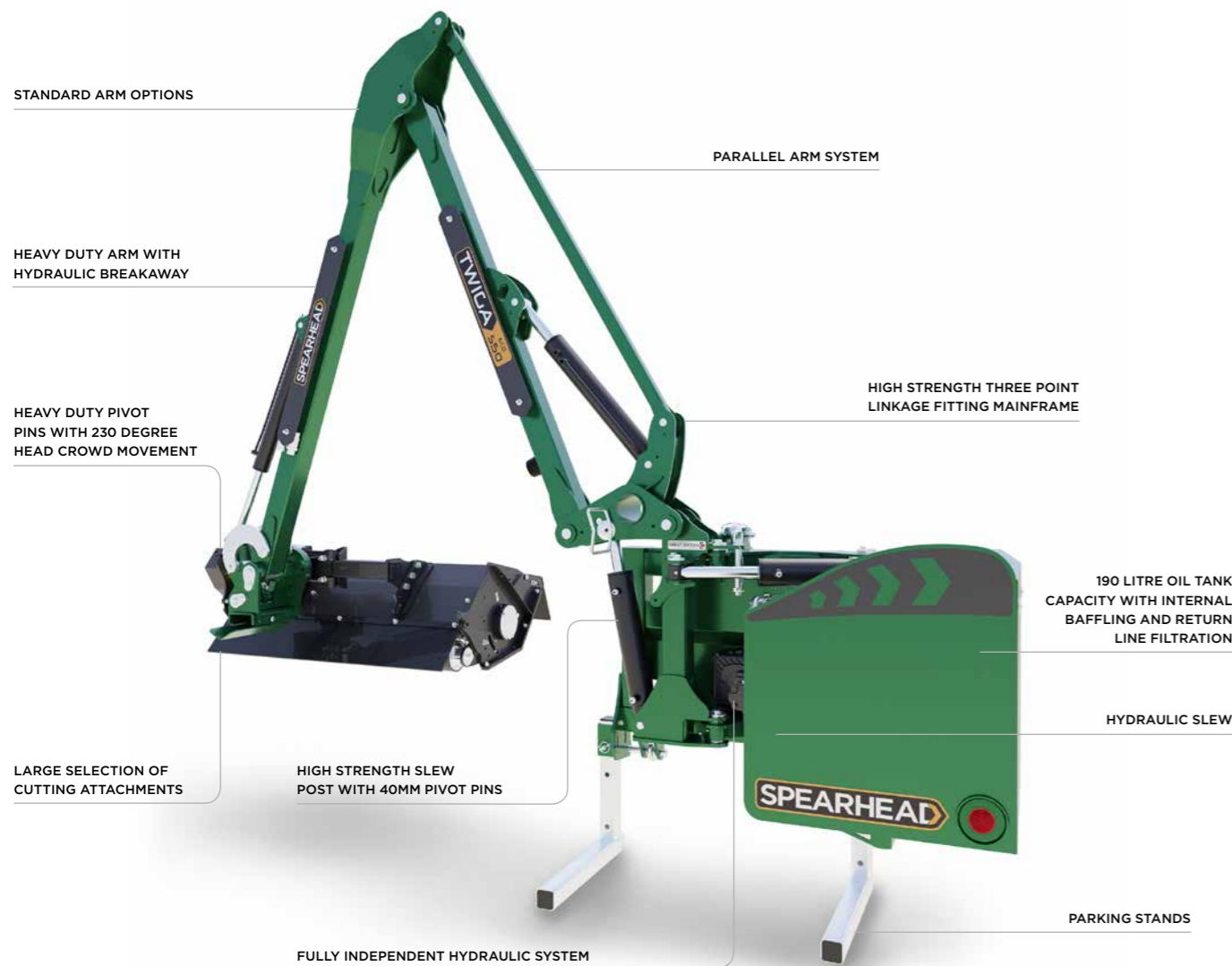

A favourite for farmers. The Twiga Eco is a lighter weight machine designed with annual cutting in mind and perfectly matched to smaller tractors.

Helping tread gently on softer grounds this machine still boasts many high level features including parallel arm geometry and a high powered 60HP hydraulic system, with reaches up to 6.0 metres.

Offering the same precision control options as the Twiga Classic, with Pilot and Minipilot the Eco remains action packed to take on the competition and nimble at the same time.

- ▶ Lightweight machine.
- ▶ Parallel arm geometry.
- ▶ Numerous upgrade options for additional spec.



MACHINE POWER
60hp



MAX REACH
6.00m (19' 7")



MINIMUM WEIGHT GUIDE	MACHINE POWER	MACHINE WEIGHT	MAXIMUM REACH	TRANSPORT WIDTH
TWIGA ECO S50 3000kg (6614lbs)	60hp	940kg (2072lbs)	5.00m (16' 5")	2.20m (7' 3")
TWIGA ECO S60 3500kg (7716lbs)	60hp	970kg (2139lbs)	6.00m (19' 7")	2.20m (7' 3")

TWIGA CLASSIC SERIES

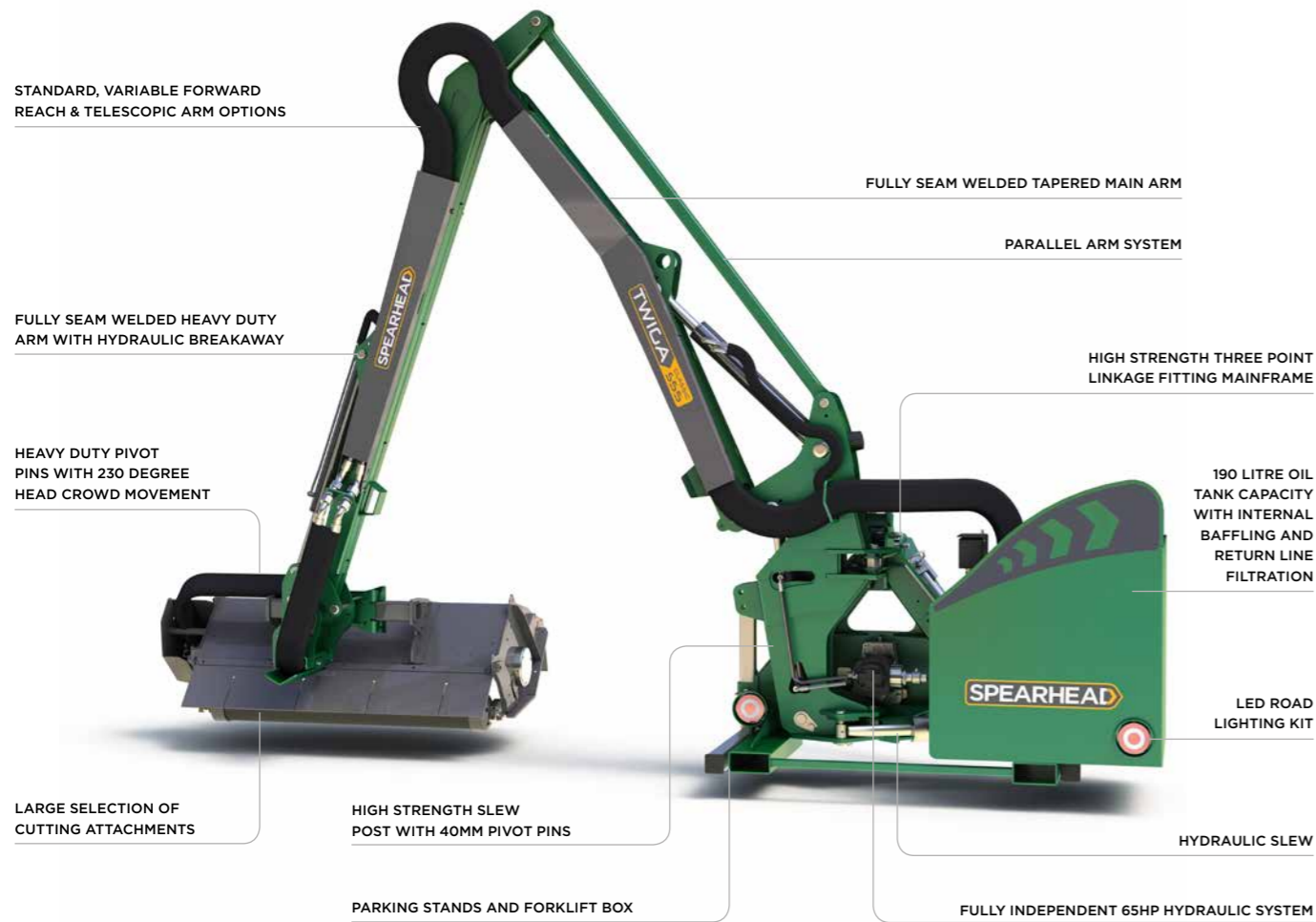

Now we're getting serious. Designed with farmers, contractors, and busy local authorities in mind, the Twiga Classic gives you all day long performance.

Stable on any terrain, the rear mounted arm has parallel arm geometry as standard. Not to mention a 65HP hydraulic system. All while reaching up to 6.5 metres.

With precise controls and reassuring operator comfort, Twiga Classic balances value and performance to perfection. With a choice of arm types and cutting attachments, it'll soon become your new best friend.

- ▶ All day long comfort and performance.
- ▶ Robust stability keeps you on track.
- ▶ Perfect your set-up with endless upgrade options.

	MINIMUM WEIGHT GUIDE	MACHINE POWER	MACHINE WEIGHT	MAXIMUM REACH	TRANSPORT WIDTH
TWIGA CLASSIC S51	4000kg (8820lbs)	65hp	1200kg (2646lbs)	5.10m (16' 7")	2.20m (7' 3")
TWIGA CLASSIC S55	4250kg (9371lbs)	65hp	1230kg (2712lbs)	5.50m (18' 0")	2.20m (7' 3")
TWIGA CLASSIC VFR55	4250kg (9371lbs)	65hp	1320kg (2911lbs)	5.50m (18' 0")	2.30m (7' 7")
TWIGA CLASSIC S60	4500kg (9923lbs)	65hp	1250kg (2756lbs)	6.00m (19' 7")	2.20m (7' 3")
TWIGA CLASSIC VFR60	4500kg (9923lbs)	65hp	1340kg (2646lbs)	6.00m (19' 7")	2.30m (7' 7")
TWIGA CLASSIC T65	4500kg (9923lbs)	65hp	1310kg (2889lbs)	6.50m (21' 4")	2.20m (7' 3")



MACHINE POWER
65hp



MAX REACH
6.50m (21' 4")

TWIGA MID SERIES

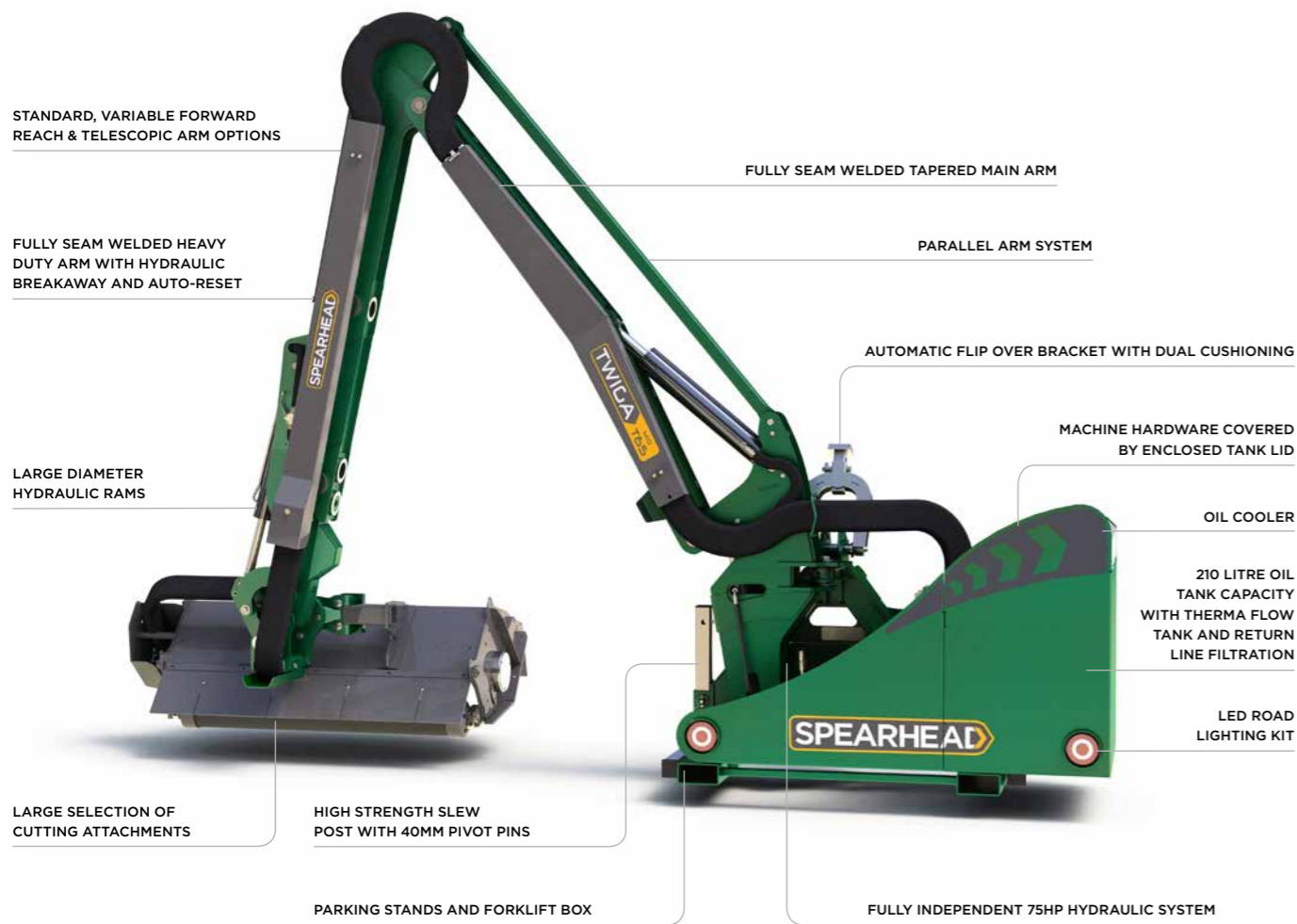

HP
MACHINE POWER
75hp

↔
MAX REACH
7.00m
(23' 0")

This is our best-selling hedge cutter for good reason. When you're after large-scale results - with reach up to 7 metres - choose Twiga Mid. No job is too large.

Ambitious farmers, contractors, and local authorities can choose its durability, thanks to a 75HP hydraulic system and rear mounting.

A cut above the Twiga Classic, operators welcome easy Multipilot or Minipilot controls.

- ▶ Handle every cutting challenge with robust confidence.
- ▶ Easy, intuitive controls for all-day operation.
- ▶ Ample options create your ultimate cutting machine.



	MINIMUM WEIGHT GUIDE	MACHINE POWER	MACHINE WEIGHT	MAXIMUM REACH	TRANSPORT WIDTH
TWIGA MID S55	4250kg (9371lbs)	75hp	1400kg (3087lbs)	5.50m (18' 0")	2.30m (7' 7")
TWIGA MID VFR55	4500kg (9923lbs)	75hp	1510kg (3330lbs)	5.50m (18' 0")	2.30m (7' 7")
TWIGA MID S60	4500kg (9923lbs)	75hp	1420kg (3131lbs)	6.00m (19' 7")	2.30m (7' 7")
TWIGA MID VFR60	4750kg (10474lbs)	75hp	1530kg (3374lbs)	6.00m (19' 7")	2.30m (7' 7")
TWIGA MID T65	4750kg (10474lbs)	75hp	1520kg (3352lbs)	6.50m (21' 4")	2.30m (7' 7")
TWIGA MID T70	5000kg (11025lbs)	75hp	1580kg (3484lbs)	7.00m (23' 0")	2.30m (7' 7")

TWIGA ORBITAL SERIES







Now, this is impressive. When you're cutting high-speed roads or intensively mowing you need every ounce of performance from your machinery. Twiga Orbital delivers in spades.

Save time by cutting on both sides of your cab. You can even switch while on the move thanks to our 305-degree Rotorflex head rotation system. Reaching to 8.3 metres you won't miss a thing.

This powerful 85HP machine delivers output at speed, hour after hour. All with ultimate comfort and simple to use controls.

- ▶ Cut faster on both sides of your cab (without stopping).
- ▶ Reach everything first time with immense flexibility.
- ▶ Work comfortably all day long with Multipilot controls.

	 MINIMUM WEIGHT GUIDE	 MACHINE POWER	 MACHINE WEIGHT	 MAXIMUM REACH	 TRANSPORT WIDTH
TWIGA ORBITAL S60	4750kg (10474lbs)	85hp	1900kg (4190lbs)	6.00m (19' 7")	1.30m (4' 3")
TWIGA ORBITAL S67	5000kg (11025lbs)	85hp	2050kg (4520lbs)	6.70m (22' 0")	1.30m (4' 3")
TWIGA ORBITAL T72	5250kg (11576lbs)	85hp	2120kg (4678lbs)	7.20m (23' 8")	1.30m (4' 3")
TWIGA ORBITAL T83	5500kg (12128lbs)	85hp	2290kg (5049lbs)	8.30m (27' 3")	1.30m (4' 3")



 MACHINE POWER
85hp

 MAX REACH
8.30m
(27' 3")

TWIGA PRO SERIES

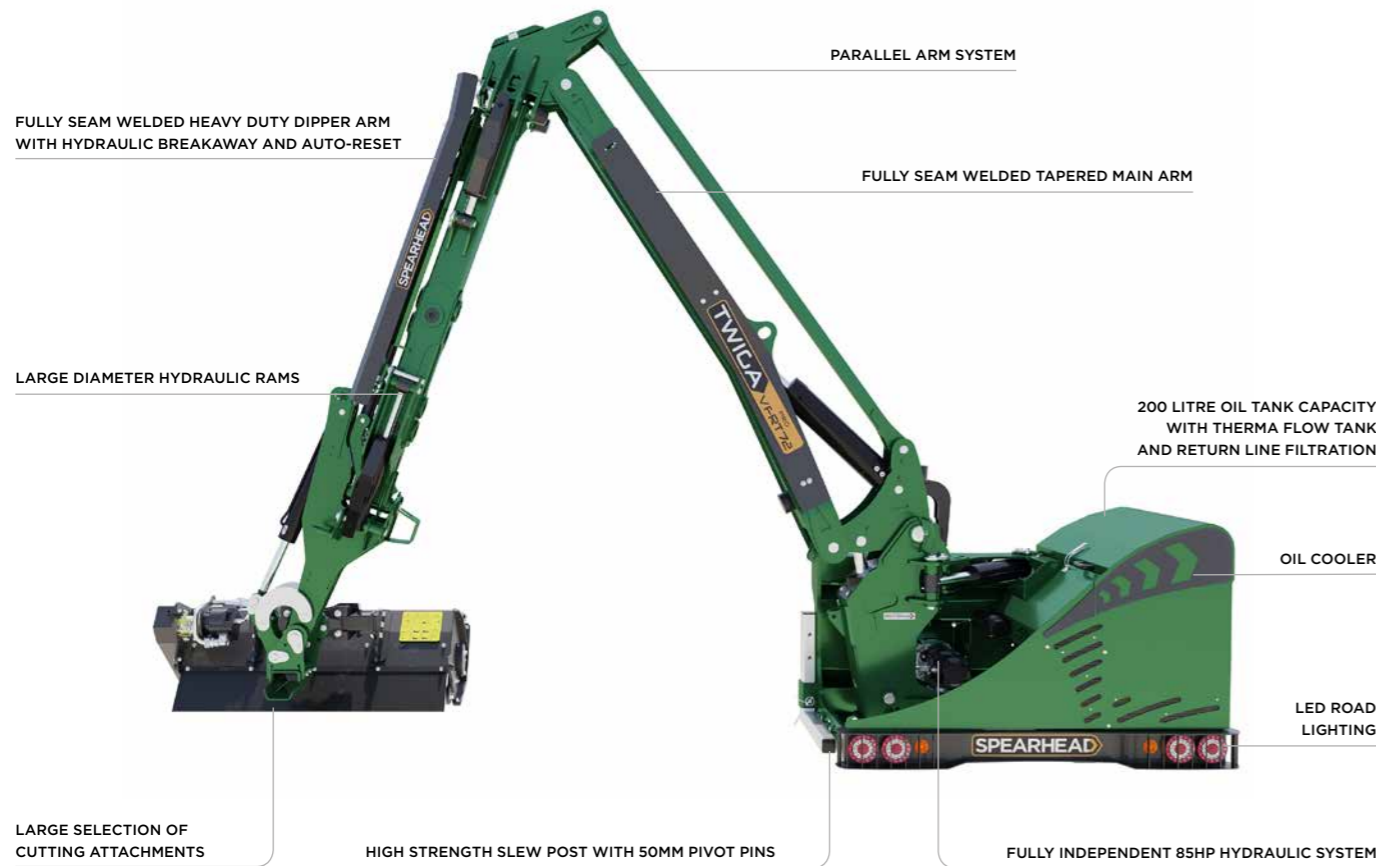

Feeling the cutting pressure? This one's for you. Next generation technology helps you exceed productivity goals with the most operator-friendly reach arm cutter available.

Chosen by large farming enterprises, leading contractors, military, and airports the 85HP Twiga Pro throws everything we have at your task.

Automation such as Autopilot and Autolevel handle your precision. You'll achieve a high-quality cut despite uneven ground or steep banks. Meanwhile, our touch screen Propilot control system enhances in-cab comfort and takes the strain. All-day shifts will fly by.

- ▶ Automated cutting for precise results.
- ▶ Power forward at faster speeds.
- ▶ Ultimate cab comfort and touch screen control.

	MINIMUM WEIGHT GUIDE	MACHINE POWER	MACHINE WEIGHT	MAXIMUM REACH	TRANSPORT WIDTH
TWIGA PRO VFR60	5000kg (11025lbs)	85hp	1720kg (3793lbs)	6.00m (19' 7")	2.30m (7' 7")
TWIGA PRO VFR65	5000kg (11025lbs)	85hp	1800kg (3969lbs)	6.50m (21' 4")	2.30m (7' 7")
TWIGA PRO T70	5000kg (11025lbs)	85hp	1870kg (4123lbs)	7.00m (23' 0")	2.30m (7' 7")
TWIGA PRO VFR72	5250kg (11576lbs)	85hp	2000kg (4410lbs)	7.20m (23' 8")	2.30m (7' 7")
TWIGA PRO T80	5250kg (11576lbs)	85hp	1930kg (4256lbs)	8.00m (26' 3")	2.30m (7' 7")



MACHINE POWER
85hp

MAX REACH
8.00m (26' 3")

TWIGA FLEX SERIES

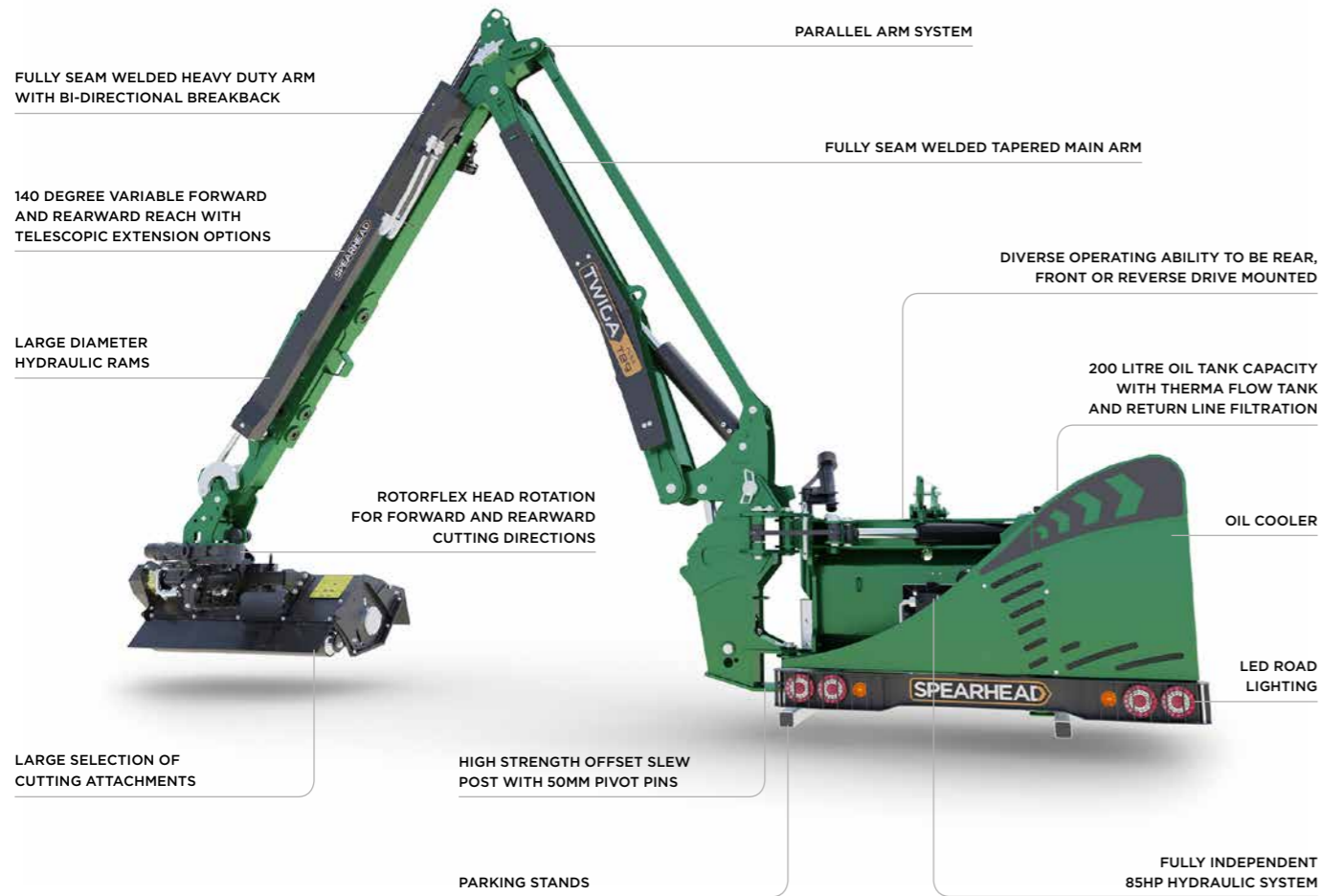

Our top-end Twiga Flex gives you the most power, performance, and productivity available. That's why it's chosen by those with the most demanding cutting schedules. Flex saves you time with robust functionality that won't let you down.

Including our top-end Propilot control system as standard, operators love spending the day with Twiga Flex. Intuitively handling so many controls, they'll finish the job with a spring in their step, with Autoflex and Autopilot also incorporated as standard.

Reaching up to 8.9 metres, work in forward or reverse, thanks to our Rotorflex system. You can front or rear mount this 85HP machine too. Find your ideal set-up and work precisely at speed.

- ▶ Top-end functionality to save time on every job.
- ▶ Double your productivity by cutting forwards and backwards.
- ▶ Work in comfort with precise, touch screen controls.



MACHINE POWER
85hp



MAX REACH
8.90m (29' 2")

	MINIMUM WEIGHT GUIDE	MACHINE POWER	MACHINE WEIGHT	MAXIMUM REACH	TRANSPORT WIDTH
TWIGA FLEX S67	5500kg (12128lbs)	85hp	2050kg (4520lbs)	6.70m (22' 0")	2.30m (7' 7")
TWIGA FLEX S74	5500kg (12128lbs)	85hp	2170kg (4785lbs)	7.40m (24' 3")	2.30m (7' 7")
TWIGA FLEX T80	5750kg (12679lbs)	85hp	2380kg (5248lbs)	8.00m (26' 3")	2.30m (7' 7")
TWIGA FLEX T89	6000kg (13230lbs)	85hp	2600kg (5733lbs)	8.90m (29' 2")	2.30m (7' 7")

TWIGA CUSTOM BUILDS

Working closely with our customers is essential to what we do. In some cases we love your ideas so much that we are able to make dreams a reality. Our experienced design team have custom designed a number of specialist machines over the past decades increasing utilisation and output.



MOUNTING TYPES

How your Twiga attaches to the tractor matters. When changing equipment regularly, you'll welcome a simple and swift manoeuvre. Should your cutting jobs be more intensive and all day long, you might favour more stability over versatility.

We offer various mounting types to suit every usage level and Twiga model. Let us help you make the right choice.

VERSATILITY

STABILITY



THREE POINT LINKAGE

Suitable for most tractors, this simple mount makes quick work of attaching your Twiga.



FOUR POINT LINKAGE

An extra link (to the drawbar) provides additional stability to your mounting arrangement.



SUBFRAME AXLE MOUNTS

Ramping up stability, a sturdy subframe bracket creates solid axle mounting.



INTEGRATED AXLE MOUNTS

Ideal for heavy use and long-reach, built in mounting arms provide ultimate stability.



DIN LOADER MOUNTS

Select a specialist mount so your Twiga works with utility vehicles, wheel loaders, and other prime movers.

MOUNT	MINI	COMPACT	ECO	CLASSIC	MID	ORBITAL	PRO	FLEX
3-POINT	■	■	■	■	■	■	■	■
4-POINT	—	□	—	□	□	□	□	□
SUBFRAME AXLE	—	—	—	□	□	□	□	□
INTEGRATED	—	—	—	—	—	—	□	□
DIN-LOADER	—	□	—	—	—	—	—	□

ARM TYPES

When specifying your ideal Twiga, arm choice is crucial. We offer everything from a simple standard arm, to more complex, flexible arms that transform productivity and operator comfort. Spearhead leads innovation in reach arm technology because your performance depends on it.

STANDARD

If you plan to use your Twiga occasionally, our simple, fixed arm does the job well. Robustly designed and fully welded, you can rely on its superior geometry and long service life.



VARIABLE FORWARD REACH (VFR)

We developed VFR to give operators complete visibility without straining over a shoulder or twisting their back. When you're in the cab all day, comfort affects productivity. So, heavy Twiga users often choose VFR as standard.

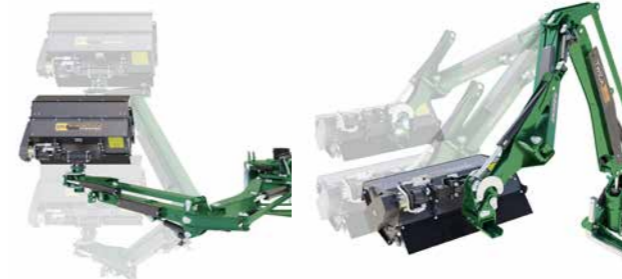

With a forward and reverse range, you gain immense cutting flexibility. With in-cab operator controls the job's done faster and more accurately.

TELESCOPIC

Need extra reach sometimes? Our telescopic arm is the answer. Compactly designed when closed in, it makes distance work a doddle as you reach out to cut high branches. Saving time, you'll deliver a cleaner job and never be outdone by a hard-to-get section.



In-cab operator controls make moving the telescopic arm easy. Becoming second nature to operators, they welcome the flexibility this arm provides, achieving their productivity goals and delivering a first class cut.

VARIABLE FORWARD REACH TELESCOPIC (VFRT)

Professional contractors, large-scale local authorities, and ambitious farmers choose the best of both worlds - a combined VFR and telescopic arm. This pairing gives them everything to complete the most challenging jobs at speed. And we all know time is money.



Repaying in performance, the VFRT provides ultimate flexibility in reach - whether forwards, in reverse, or up high.

ARM	MINI	COMPACT	ECO	CLASSIC	MID	ORBITAL	PRO	FLEX
STANDARD	■	■	■	■	■	■	■	■
VFR	■	—	—	■	■	—	■	—
TELESCOPIC	—	—	—	■	■	■	■	■
VFR TELESCOPIC	—	—	—	—	—	—	■	—

CONTROL SYSTEMS

Choose how you want to control your Twiga machine. Some customers opt for a simple hydraulic system. Others want everything our touch screen Propilot can give them. With several intuitive options available, consider which one would give you the comfort and functionality you need.



PROGRESSIVE CABLE CONTROLS

Our simplest control system with multi-lever functionality and a progressive cable response. Enjoy fingertip operation and a compact design.



PILOT HYDRAULIC PROPORTIONAL CONTROLS

Benefit from superior comfort with this robustly built unit. Incredibly responsive to use, you can mount it on the seat armrest. A reliable pilot controller for precision results.



MINIPILOT ELECTRIC PROPORTIONAL CONTROLS

This compact electric proportional system easily mounts in most cabs (and quickly disconnects for secure storage). It sports a mini joystick to deliver accurate control from subtle movements.



MULTIPILOT HYDRAULIC PROPORTIONAL CONTROLS

On the Twiga Mid series and above, benefit from the addition of an electric rotor control with this ever-popular low pressure hydraulic unit. Mount it on the armrest to enjoy immense comfort and feel.

CONTROL	MINI	COMPACT	ECO	CLASSIC	MID	ORBITAL	PRO	FLEX
PROGRESSIVE CABLE	■	■	—	—	—	—	—	—
MINIPILOT	—	□	□	□	■	—	—	—
PILOT	—	—	■	■	—	—	—	—
MULTIPILOT	—	—	—	—	□	■	—	—
PROPILOT	—	—	—	—	—	—	■	■

CONTROL SYSTEMS



PROPILOT ELECTRIC PROPORTIONAL CONTROLS

Leading the market with a 10-inch touch screen, life in the cab just got much easier with Propilot on board. Giving you everything (and more) Propilot puts you in pin-point control.

Customise the location of joystick functions so it's exactly right for you and monitor all your operational metrics in real time. Thanks to an integrated light sensor, you'll see the screen whatever the weather.

Rugged and water-resistant, you can even use the touch screen with gloves.

When your workload stacks up, track activity on Propilot. Able to monitor up to six jobs at once, record your time via the touch screen and watch daily profitability.

Reducing downtime, find faults faster with Propilot. Operators can access live diagnostics whenever they want. It's a major improvement on the typical 'laptop plug-in' method of previous systems.

Robust, comprehensive, easy to use. That sums up our top-choice Propilot controller.

“I really like the new Propilot system. It's user-friendly for our operators and the touch screen tells you everything. If problems do occur, the system gives you error codes to ensure a faster fix. This saves us time and money.”

Richard Elkington - Lincolnshire, UK



FLOAT SYSTEMS

Uneven ground challenges the most attentive operator. When you're working all day, manually maintaining the perfect head position is exhausting. Not to mention slower going. That's why we offer various automatic float systems. Maintaining your perfect cutting position whatever the contours, you'll push on faster with a float system in play.

HEAD FLOAT

Benefit from automatic contour levelling. Your cutting attachment will move freely and pivot in response to ground conditions. No need to keep adjusting it manually. Achieve a better cut with less effort.



ARM FLOAT

Delegate arm height control to automation. Over contours, your machine arm will fall and rise to the perfect cutting height. No more badly cut ruts, you'll achieve perfection every time.



FLOAT SYSTEM	MINI	COMPACT	ECO	CLASSIC	MID	ORBITAL	PRO	FLEX
HEAD FLOAT	—	■	—	■	■	■	■	■
ARM FLOAT	—	□	—	□	□	■	—	—
AUTOPILOT	—	—	—	—	—	—	■	■

FLOAT SYSTEMS

AUTOPILOT

The first fully automatic verge float system - and now it's even better! Autopilot keeps you working at speed, whatever the terrain. Using the most advanced technology, it maintains your optimum head and arm position, so you don't have to.

A flagship, electronic system, Autopilot monitors pressures every few milliseconds and adjusts your cutting position accordingly. With fewer parameters to manage manually, cab life is easier with no compromise on quality.

Compared to previous mechanical float systems, Autopilot reduces arm weight by more than 70kg. With less strain, this prolongs the life of your machine.

The big win comes from faster forward speeds and higher productivity. When ground conditions allow, you can travel up to 22km per hour with Autopilot enabled. It's ideal when you're tackling heavyweight grass work.



One click via the joystick or screen switches Autopilot on or off. Should you meet an obstacle, disengage it instantly (and re-engage it in seconds). You can also run Autopilot on three different levels - hard, medium, and soft - depending on ground conditions.

Once you've experienced Autopilot, you'll never want any other float system again.



PRECISION CUTTING SYSTEMS

AUTOLEVEL

Precision is crucial for professional hedge cutting. And head angle is a huge contributor. That's why Spearhead has lead automation control development in this area.

Exclusively developed by Spearhead engineers, Autolevel offers ground-breaking innovation in hedge cutting technology. Automatically maintaining your precise hedge-cutting angle, achieve superb results without suffering from hours of manual adjustment.

It's so easy to use. Preset up to three fixed angles and let Autolevel take care of it. When you want extreme flexibility, simply slide through degree changes

Want a perfectly flat hedge top? That's easy with Autolevel. Even when the ground's uneven. And when you change the arm height, Autolevel stays in play.



Technology-driven contractors love this advanced feature. Developed to meet customer demand, Autolevel highlights our determination to build the best possible machines - always.

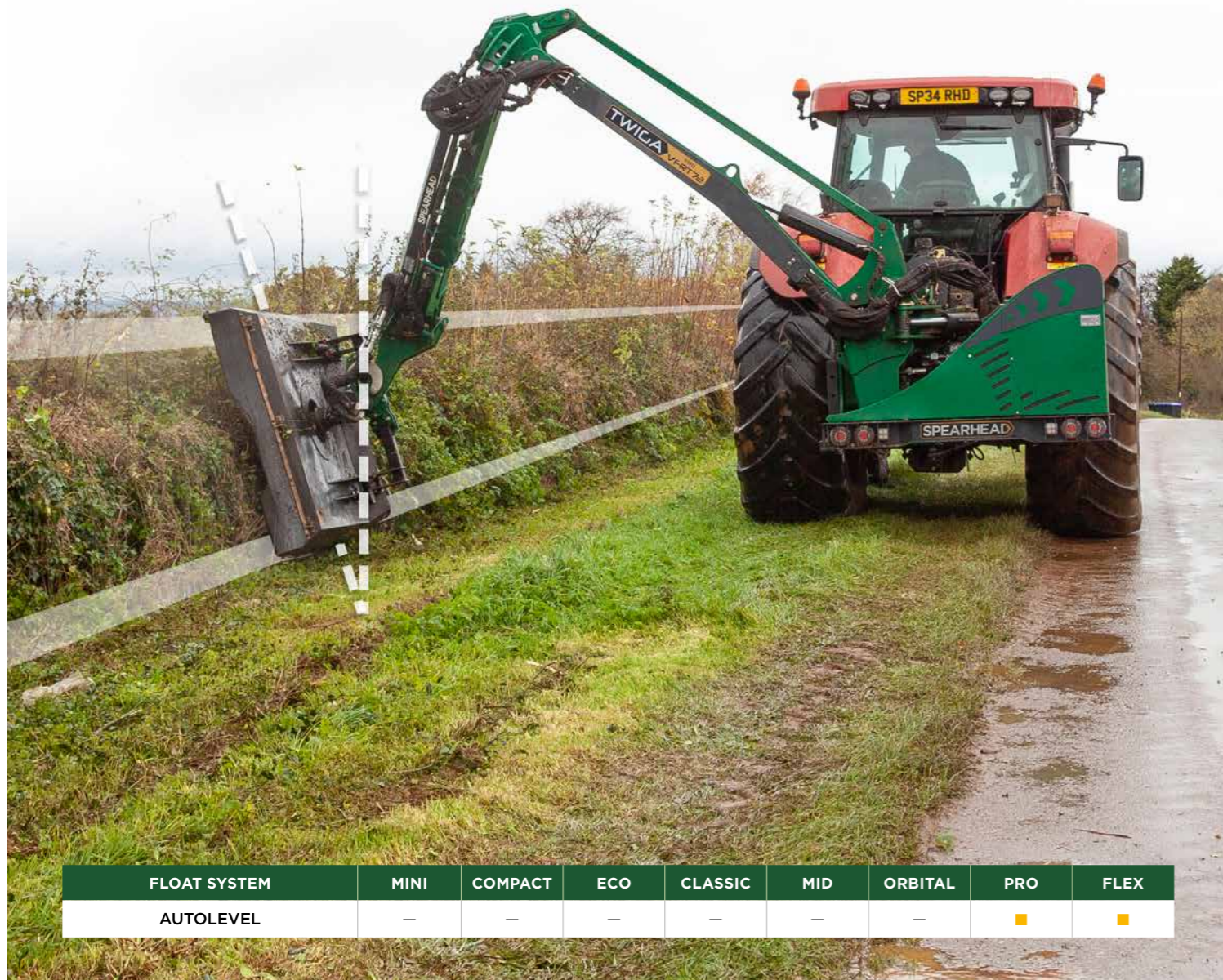

FLOAT SYSTEM	MINI	COMPACT	ECO	CLASSIC	MID	ORBITAL	PRO	FLEX
AUTOLEVEL	—	—	—	—	—	—	■	■

PRECISION CUTTING SYSTEMS

NARROW LANE BRACKET

When you don't have sufficient width to work in, a narrow lane bracket comes in handy.

Fitting between arm and attachment, it allows you to work within the width of your tractor, great for lanes and tight avenues.

Tuck the head behind the tractor wheel to tackle hedge sides. Or raise it up in front when you're working high. Exposing more of the cutting flail, this is particularly useful when cutting through heavy growth. It makes speedy work of the unruliest hedge.

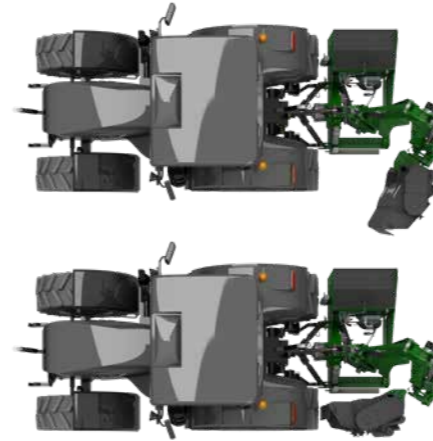

CUTTING SYSTEM	MINI	COMPACT	ECO	CLASSIC	MID	ORBITAL	PRO	FLEX
NARROW LANE BRACKET	—	—	—	□	□	—	□	—

TEMPERATURE CONTROL SYSTEMS

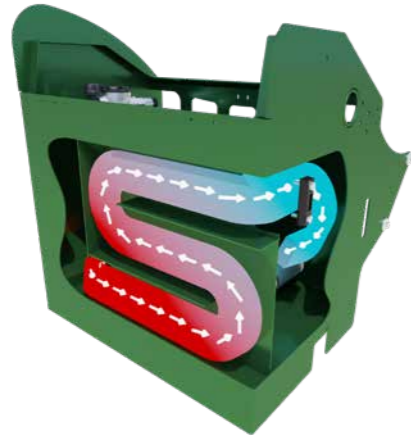

THERMA-FLOW TANK DESIGN

The key to a long service life is keeping your machine cool. This also promotes efficiencies and lowers downtime risks such as leaks from perished seals.

We include our Therma-Flow tanks on Mid, Pro and Flex as standard.

Moving hot oil through the Therma-Flow tank, heat disperses to the outside rather than remaining in the chamber. This ensures your machine runs at its coolest.

OIL COOLER

- ▶ For machines working in demanding environments.
- ▶ Electric temperature sensor.
- ▶ Fitted in-line and cools oil prior to returning into tank.

TEMPERATURE CONTROL SYSTEM	MINI	COMPACT	ECO	CLASSIC	MID	ORBITAL	PRO	FLEX
THERMA FLOW TANK	—	—	—	—	■	—	■	■
OIL COOLER	—	—	—	□	■	■	■	■

DEBRIS CONTROL

DEBRIS BLOWER

For safety reasons many roads authorities insist you use a debris blower. Keeping roads and pathways clear as you work it also ensures a tidy job.

Fitted to the back of the oil tank or even integrated in the rear of the tank on Pro and Flex for greater output.



ATTACHMENT	MINI	COMPACT	ECO	CLASSIC	MID	ORBITAL	PRO	FLEX
DEBRIS BLOWER	—	—	—	□	□	□	—	—
INTEGRATED DEBRIS BLOWER	—	—	—	—	—	—	□	□

QUICK ATTACHMENT SYSTEMS



MECHANICAL QUICK ATTACH

Save 75% of your changeover time. Switching attachments becomes a task of minutes.



HYDRAULIC QUICK COUPLINGS

Join your hoses by hand without any mess. Just plug and go. You won't spill a drop of oil.

VISIBILITY SYSTEMS



HIGHWAY KIT

Enhance your visibility on the road. This kit includes a directional arrow, warning chevrons, and flashing LEDs.

BOOM LIGHT

Add a Boom Light providing additional visibility to allow you to extend your working day, or work through the night.



SPECIAL COLOURS

We can paint your Twiga machine in bespoke RAL colours to suit your requirements.

SPECIALIST ATTACHMENTS

Take off your blinkers and see how versatile a Twiga machine can be. With a host of different attachments, it can confidently tackle a variety of jobs, better utilising your investment.

From grass cutting and hedge cutting, to ditch clearing and tree cutting, there's an attachment to handle every situation and save you time.

You have a choice of flailheads – compact and powerdrive, plus a sturdy rotary head. Each adds huge value to your grass or hedge cutting operations.

Consider the cutterbar when working in public areas such as school playing fields and parks. It runs more quietly and doesn't repel debris. As for the sawblade, it can handle six-inch branches with ease. You'll soon have those challenging tasks under control.

Should you manage ditches, look no further than the ditch cleaner. It makes slick work of an important water management job.

When you're equipped with the right attachments, your Twiga will always be on hand to boost your productivity.

ATTACHMENT COMPATABILITY								
ATTACHMENT	MINI	COMPACT	ECO	CLASSIC	MID	ORBITAL	PRO	FLEX
COMPACT FLAILHEAD	–	□	–	–	–	–	–	–
POWERDRIVE FLAILHEAD	–	–	□	□	□	□	□	□
MINI CUTTERBAR	■	–	–	–	–	–	–	–
SP CUTTERBAR	–	□	□	□	□	□	□	□
SP HD CUTTERBAR	–	–	–	□	□	□	□	□
TRISAW SAWBLADE	–	□	□	□	□	□	□	□
QUADSAW SAWBLADE	–	–	□	□	□	□	□	□
HD ROTARY HEAD	–	–	–	□	□	□	□	□
DITCH CLEANER	–	–	–	□	□	□	□	□

COMPACT FLAILHEAD



▲ TWIGA Compact with a Compact 100 Flailhead



POWERDRIVE FLAILHEAD



▲ Powerdrive 120 Flailhead double spiral flail arrangement

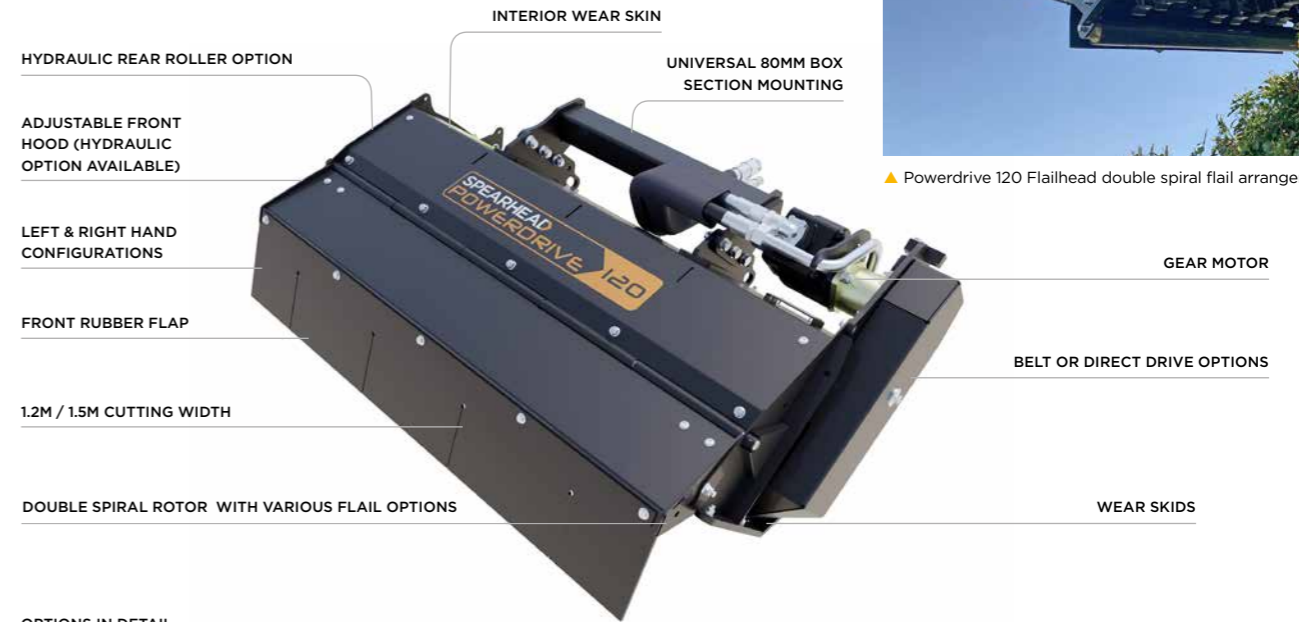

OPTIONS IN DETAIL

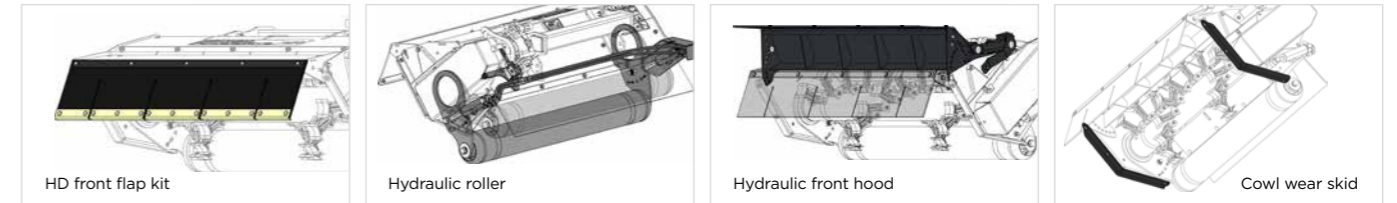

COMPACT 100

COMPACT 120

	CUTTING WIDTH	WEIGHT OF ATTACHMENT*	NUMBER OF FLAILS	ROLLER CUTTING HEIGHT	APPLICATION	MINIMUM FLOW	PRESSURE
COMPACT 100	1.00m (3' 3")	140kg (309lbs)	28	-20 - +160mm (-3/4" - +6' 5/16")	Grass / Hedge	40 l/min	200 bar
COMPACT 120	1.20m (4')	196kg (432lbs)	24	-20 - +160mm (-3/4" - +6' 5/16")	Grass / Hedge	40 l/min	200 bar

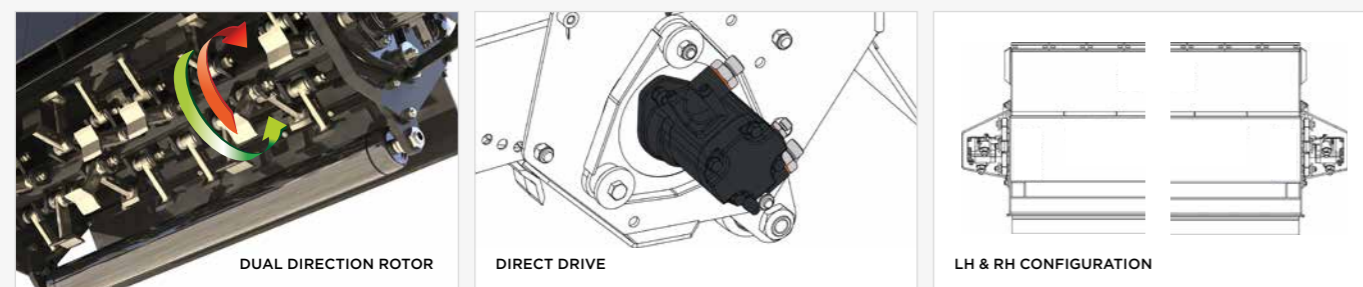

ATTACHMENT	MINI	COMPACT	ECO	CLASSIC	MID	ORBITAL	PRO	FLEX
COMPACT FLAILHEAD	—	□	—	—	—	—	—	—

*Weights may vary dependent on machine type and specification

	CUTTING WIDTH	WEIGHT OF ATTACHMENT*	NUMBER OF FLAILS	ROLLER CUTTING HEIGHT	APPLICATION	MINIMUM FLOW	PRESSURE
POWERDRIVE 120	1.20m (4')	390kg (860lbs)	28	-20 - +160mm (-3/4" - +6' 5/16")	Grass / Hedge	90 l/min	220 bar
POWERDRIVE 150	1.50m (5')	440kg (970lbs)	36	-20 - +160mm (-3/4" - 6' 5/16")	Grass / Hedge	90 l/min	220 bar

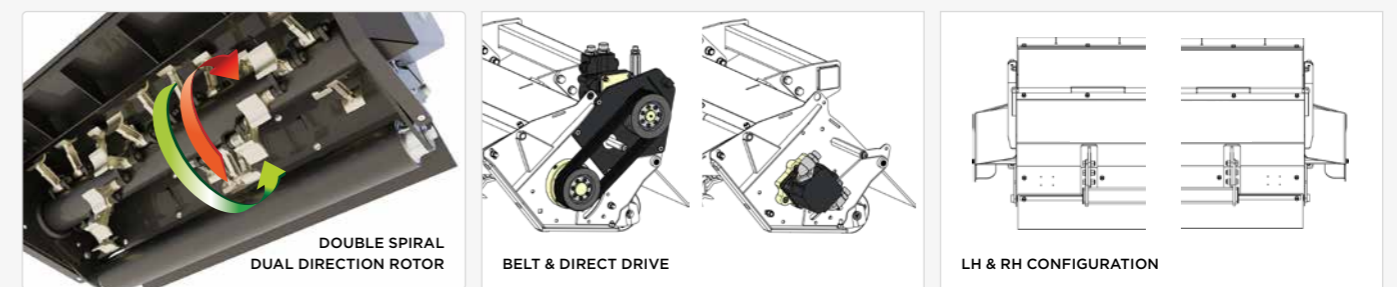

ATTACHMENT	MINI	COMPACT	ECO	CLASSIC	MID	ORBITAL	PRO	FLEX
POWERDRIVE FLAILHEAD	—	—	□	□	□	□	□	□

*Weights may vary dependent on machine type and specification

CUTTERBARS

SP HD CUTTERBAR

FULLY ENCLOSED HYDRAULIC SIDESHIFT MECHANISM

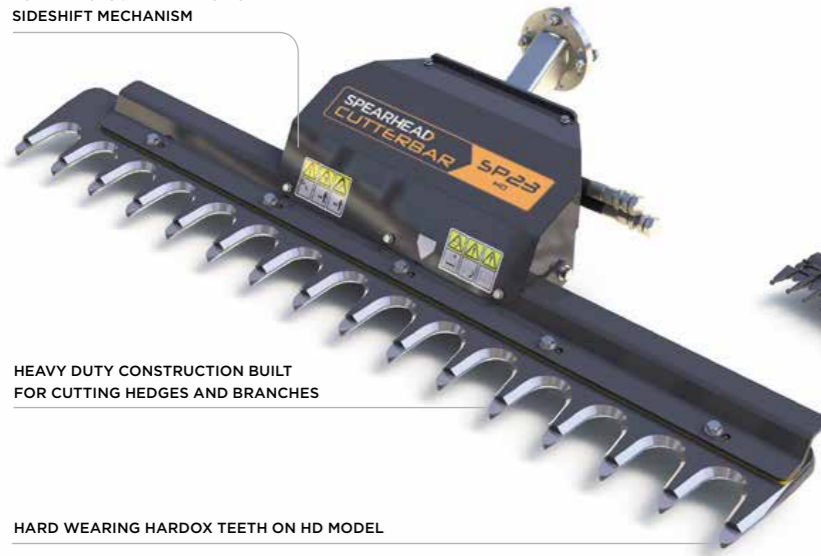

HEAVY DUTY CONSTRUCTION BUILT FOR CUTTING HEDGES AND BRANCHES

HARD WEARING HARDFOX TEETH ON HD MODEL



▲ Branch cutting with the SP23 cutterbar

SP CUTTERBAR

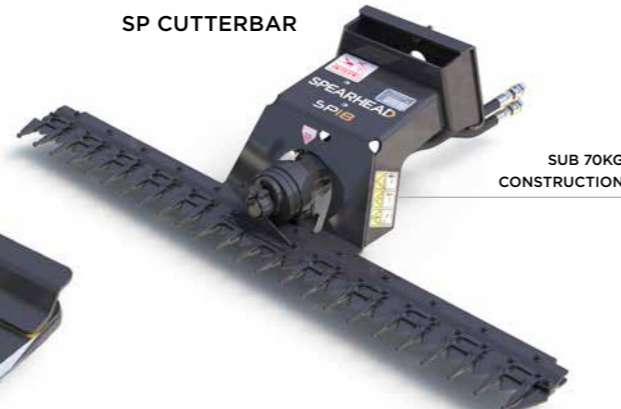

SUB 70KG CONSTRUCTION

SAWBLADES

SP QUADSAW

2.0 & 2.5M CUTTING WIDTHS

GROUND SKID

GEAR MOTOR

MAINTENANCE COVER

1.5M CUTTING WIDTH

SP TRISAW

DOWNWARD CUTTING DIRECTION

TUNGSTEN CARBIDE TIPPED BLADES
SP20: 4 X 490MM / SP25: 4 X 620MM

TUNGSTEN CARBIDE TIPPED BLADES 3 X 490MM



▲ Tree cutting with the SP20 Quadsaw

	CUTTING WIDTH	WEIGHT OF ATTACHMENT*	NUMBER OF BLADES	CUTTING CAPACITY	APPLICATION	MINIMUM FLOW	PRESSURE
SP12 MINI	1.20m (3' 11")	44kg (97lbs)	16	30mm (1' 3/16")	Hedge	25 l/min	180 bar
SP16 MINI	1.60m (5' 3")	55kg (121lbs)	21	30mm (1' 3/16")	Hedge	25 l/min	180 bar
SP15	1.50m (4' 9")	60kg (132lbs)	19	40mm (1' 9/16")	Hedge	25 l/min	180 bar
SP18	1.80m (5' 9")	64kg (141lbs)	23	40mm (1' 9/16")	Hedge	50 l/min	180 bar
SP21	2.10m (6' 9")	68kg (150lbs)	27	40mm (1' 9/16")	Hedge	50 l/min	180 bar
SP17 HD	1.70m (5' 6")	180kg (397lbs)	26	100mm (3' 15/16")	Hedge	50 l/min	300 bar
SP23 HD	2.30m (7' 5")	220kg (485lbs)	30	100mm (3' 15/16")	Hedge	50 l/min	300 bar
SP27 HD	2.70m (8' 8")	260kg (573lbs)	36	100mm (3' 15/16")	Hedge	50 l/min	300 bar

	CUTTING WIDTH	WEIGHT OF ATTACHMENT*	NUMBER OF BLADES	CUTTING CAPACITY	APPLICATION	MINIMUM FLOW	PRESSURE
SP15 TRISAW	1.50m (4' 9")	190kg (419lbs)	3	150mm (5' 15/16")	Hedge	84-87 l/min	180 bar
SP20 QUADSAW	2.00m (6' 5")	215kg (474lbs)	4	150mm (5' 15/16")	Hedge	84-87 l/min	220 Bar
SP25 QUADSAW	2.50m (7' 9")	242kg (534lbs)	4	150mm (5' 15/16")	Hedge	84-87 l/min	220 Bar

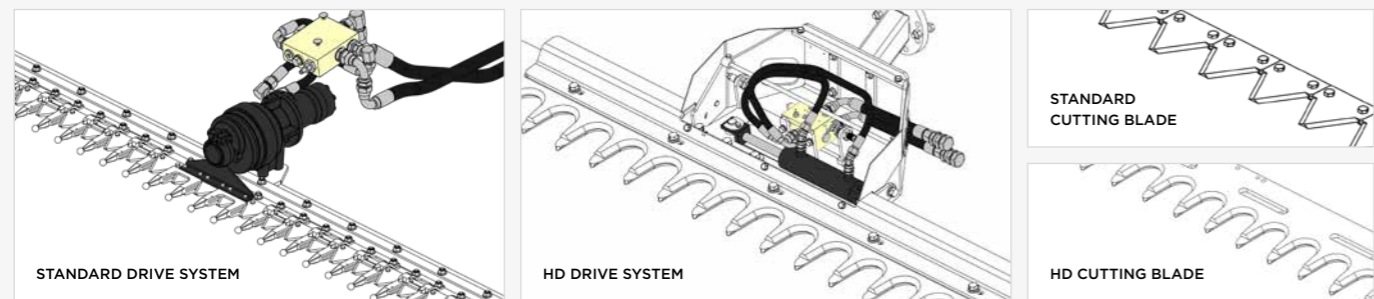

ATTACHMENT	MINI	COMPACT	ECO	CLASSIC	MID	ORBITAL	PRO	FLEX
SP12 MINI CUTTERBAR	■	—	—	—	—	—	—	—
SP16 MINI CUTTERBAR	■	—	—	—	—	—	—	—
SP15 CUTTERBAR	—	□	□	□	□	□	□	□
SP18 CUTTERBAR	—	□	□	□	□	□	□	□
SP21 CUTTERBAR	—	□	□	□	□	□	□	□
SP17 HD CUTTERBAR	—	—	□	□	□	□	□	□
SP23 HD CUTTERBAR	—	—	□	□	□	□	□	□
SP27 HD CUTTERBAR	—	—	□	□	□	□	□	□

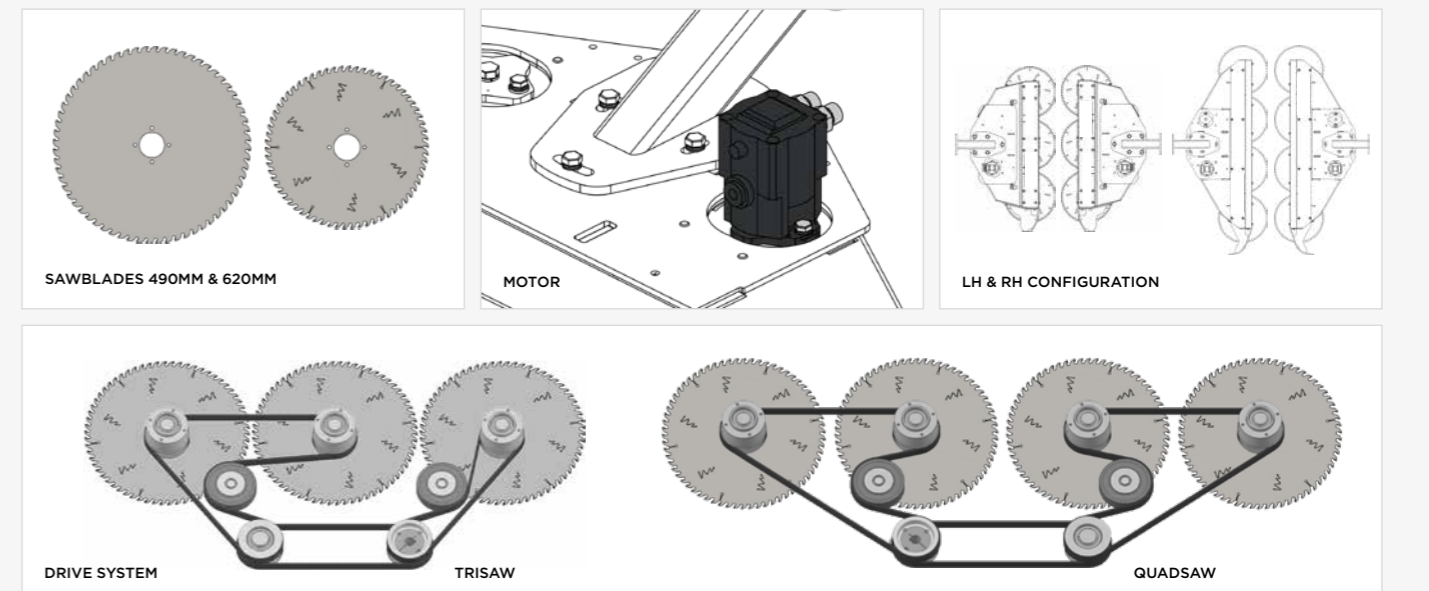

ATTACHMENT	MINI	COMPACT	ECO	CLASSIC	MID	ORBITAL	PRO	FLEX
SP15 TRISAW	—	□	□	□	□	□	□	□
SP20 QUADSAW	—	—	□	□	□	□	□	□
SP25 QUADSAW	—	—	□	□	□	□	□	□

ROTARY HEAD



▲ Twiga Classic fitted with the SP12 Rotary Head

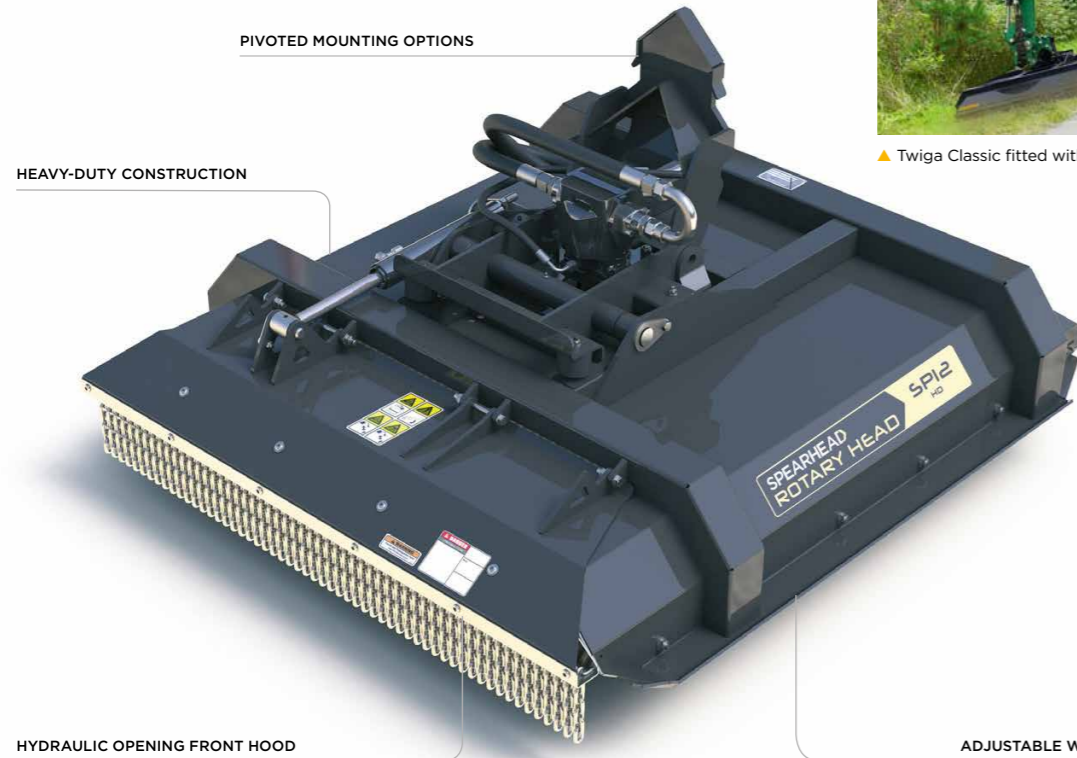

PIVOTED MOUNTING OPTIONS

HEAVY-DUTY CONSTRUCTION

HYDRAULIC OPENING FRONT HOOD

ADJUSTABLE WEAR SKIDS

DITCH CLEANER



▲ High pressure ditch maintenance



HYDRAULIC HEAD SLEW

STORAGE STAND

HYDRAULIC ADJUSTABLE EJECTION HOOD

LH / RH BUILD CONFIGURATIONS

FOUR CUTTING BLADES AND THROWING PADDLES

600MM / 24" CUTTING DISC DIAMETER

VARIOUS BLADE AND PADDLE OPTIONS

	CUTTING WIDTH	WEIGHT OF ATTACHMENT*	NUMBER OF BLADES/CHAINS	CUTTING CAPACITY	CUTTING HEIGHT	APPLICATION	MINIMUM FLOW	PRESSURE
SP12 HD	1.20m (3' 11")	408kg (900lbs)	3 (blades or chains)	150mm (5' 15/16")	13 - 65mm (1/2" - 2' 9/16")	Grass / Hedge	90 l/min	300 bar
SP15 HD	1.50m (4' 11")	483kg (1065lbs)	3 (blades or chains)	150mm (5' 15/16")	13 - 65mm (1/2" - 2' 9/16")	Grass / Hedge	90 l/min	300 bar

CUTTING DIAMETER	WEIGHT OF ATTACHMENT*	NUMBER OF CUTTING BLADES	APPLICATION	MINIMUM FLOW	PRESSURE
600mm (24")	326kg (719lbs)	4	Ditch / Grip	90 l/min	220 bar

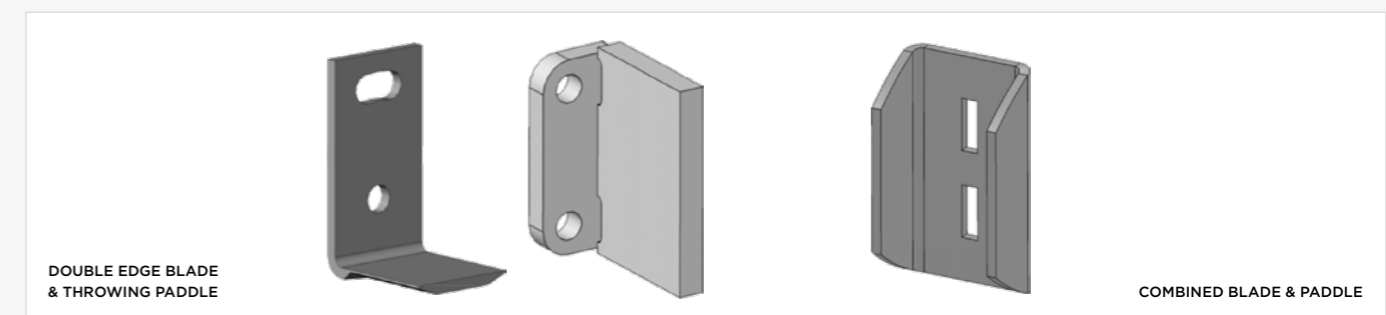
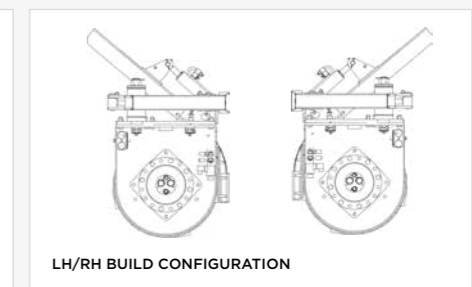
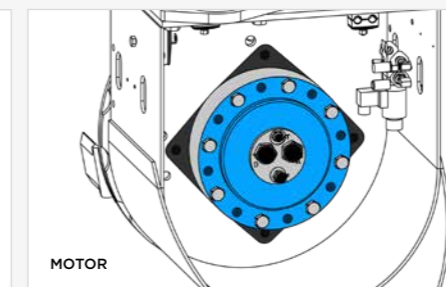
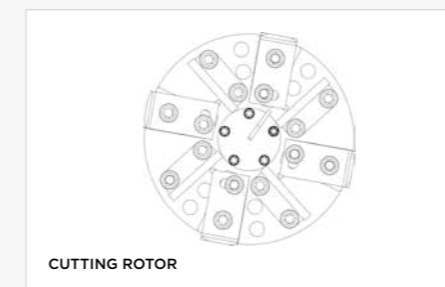
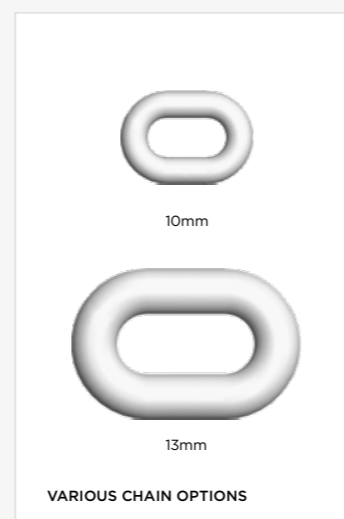
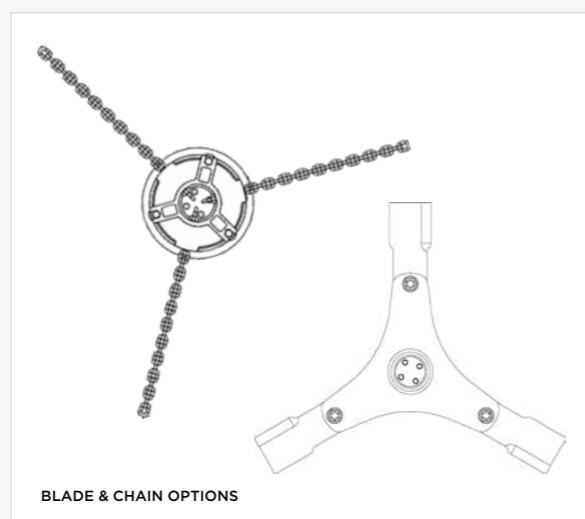
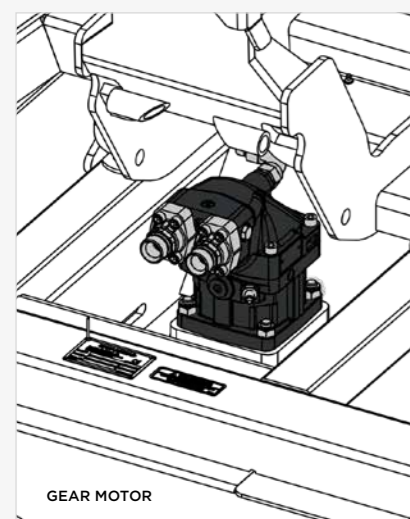

ATTACHMENT	MINI	COMPACT	ECO	CLASSIC	MID	ORBITAL	PRO	FLEX
SP12 HD ROTARY HEAD	—	—	—	□	□	□	□	□
SP15 HD ROTARY HEAD	—	—	—	□	□	□	□	□

ATTACHMENT	MINI	COMPACT	ECO	CLASSIC	MID	ORBITAL	PRO	FLEX
DITCH CLEANER	—	—	—	—	□	□	□	□

TWIGA MINI SERIES

■ Standard Equipment □ Optional Equipment – Not available

FEATURES	S26	S37	VFR37
SPECIFICATION			
Machine weight*	210kg (463lbs)	260kg (573lbs)	310kg (684lbs)
TRACTOR REQUIREMENTS			
Minimum tractor weight guide	500kg (1103lbs)	900kg (1985lbs)	1100kg (2426lbs)
TWIGA CONTROL SYSTEMS			
Tractor spool control system	■	■	■
Progressive cable control system	□	□	□
MOUNTING			
Rear three point linkage	■	■	■
Front three point linkage	■	■	■
ARM TYPES			
Standard arm = S	■	■	–
Telescopic arm = T	–	–	–
Variable forward reach arm = VFR	–	–	■
Parallel arm system	■	■	■
Hydraulic arm system	–	–	–
HYDRAULIC SYSTEM			
Tractor hydraulic drive	■	■	■
Independent hydraulic drive	□	□	□
Flow rate	15 l/min	20 l/min	20 l/min
Pressure requirement	180 bar	180 bar	180 bar
KEY FEATURES & OPTIONS			
Attachment type	Cutterbar	Cutterbar	Cutterbar
Mechanical breakaway	■	■	■
Cutterbar cutting width	1.20m (3' 11")	1.60m (5' 3")	1.60m (5' 3")
Cutterbar weight	44kg (97lbs)	55kg (121lbs)	55kg (121lbs)
Blade quantity	16	21	21
Maximum cutting capacity	30mm (1' 3/16")	30mm (1' 3/16")	30mm (1' 3/16")
SAFETY EQUIPMENT			
Cab guard kit	■	■	■

*Inclusive of cutterbar fitted
Weights may vary dependent on machine type and specification



For full machine dimensions please scan the code or visit www.spearheadmachinery.com/dimensions

TWIGA COMPACT SERIES

■ Standard Equipment □ Optional Equipment – Not available

FEATURES	S32	S42	S49	S36 FM	S46 FM	S36 COMBI	S46 COMBI	S32 BASIC	S42 BASIC	S36 BASIC	S46 BASIC
SPECIFICATION											
Machine weight*	480kg (1058lbs)	520kg (1147lbs)	540kg (1191lbs)	500kg (1103lbs)	540kg (1191lbs)	620kg (1367lbs)	660kg (1455lbs)	420kg (926lbs)	460kg (1014lbs)	440kg (970lbs)	480kg (1058lbs)
TRACTOR REQUIREMENTS											
Minimum tractor weight guide	1500kg (3308lbs)	1750kg (3859lbs)	2000kg (4410lbs)	1500kg (3308lbs)	1750kg (3859lbs)	1500kg (3308lbs)	1750kg (3859lbs)	1500kg (3308lbs)	1750kg (3859lbs)	1500kg (3308lbs)	1750kg (3859lbs)
TWIGA CONTROL SYSTEMS											
Progressive cable control system	□	□	□	□	□	□	□	–	–	–	–
Minipilot electric proportional control system	■	■	■	■	■	■	■	□	□	□	□
MOUNTING											
Rear three point linkage	■	■	■	–	–	■	■	■	■	■	■
Front three point linkage	□	□	□	■	■	■	■	□	□	□	□
Adaptor kit	–	–	–	–	–	–	–	□	□	□	□
ARM TYPES											
Standard arm = S	■	■	■	■	■	■	■	■	■	■	■
Parallel arm system	■	■	■	■	■	■	■	■	■	■	■
HYDRAULIC SYSTEM											
System	Gear	Gear	Gear	Gear	Gear	Gear	Gear	–	–	–	–
Pump	Aluminium	Aluminium	Aluminium	Aluminium	Aluminium	Aluminium	Aluminium	–	–	–	–
Pump arrangement	Twin	Twin	Twin	Twin	Twin	Twin	Twin	–	–	–	–
Drive type	Fully Independent	Fully Independent	Fully Independent	Fully Independent	Fully Independent	Fully Independent	Fully Independent	Tractor Supply	Tractor Supply	Tractor Supply	Tractor Supply
Tank capacity	60 litres (106 pints)	60 litres (106 pints)	60 litres (106 pints)	60 litres (106 pints)	60 litres (106 pints)	60 litres (106 pints)	60 litres (106 pints)	–	–	–	–
Horsepower	35hp	35hp	35hp	35hp	35hp	35hp	35hp	–	–	–	–
Rotor circuit flow rate requirement	–	–	–	–	–	–	–	40 l/min	40 l/min	40 l/min	40 l/min
Ram circuit flow rate requirement	–	–	–	–	–	–	–	10 l/min	10 l/min	10 l/min	10 l/min
Rotor circuit pressure requirement	–	–	–	–	–	–	–	200 bar	200 bar	200 bar	200 bar
Ram circuit pressure requirement	–	–	–	–	–	–	–	145 bar	145 bar	145 bar	145 bar
KEY FEATURES & OPTIONS											
Autoreset	■	■	■	■	■	■	■	■	■	■	■
Head float	■	■	■	■	■	■	■	■	■	■	■
Arm float	□	□	□	□	□	□	□	□	□	□	□
Oil cooler	□	□	□	□	□	□	□	□	□	□	□
Dual direction rotor (electric)	■	■	■	■	■	■	■	–	–	–	–
Hydraulic oil	■	■	■	■	■	■	■	–	–	–	–
Biodegradable oil	□	□	□	□	□	□	□	–	–	–	–
Mechanical quick release kit (1 set - M/F)	□	□	□	□	□	□	□	□	□	□	□
Hydraulic quick release kit (1 set - M/F)	□	□	□	□	□	□	□	□	□	□	□
SAFETY EQUIPMENT											
Cab guard kit	■	■	■	■	■	■	■	■	■	■	■
Debris blower and mounting kit	–	–	–	–	–	–	–	–	–	–	–
Warning arrow kit	□	□	□	□	□	□	□	□	□	□	□
LED road lighting kit	□	□	□	□	□	□	□	□	□	□	□
Flashing LEDs	□	□	□	□	□	□	□	□	□	□	□

*Weights may vary dependent on machine type and specification



For full machine dimensions please scan the code or visit www.spearheadmachinery.com/dimensions

TWIGA ECO SERIES

■ Standard Equipment □ Optional Equipment — Not available

FEATURES	S50	S60
SPECIFICATION		
Machine weight*	940kg (2072lbs)	970kg (2139lbs)
TRACTOR REQUIREMENTS		
Minimum tractor weight guide	3000kg (6614lbs)	3500kg (7716lbs)
TWIGA CONTROL SYSTEMS		
Pilot hydraulic proportional control system	■	■
MiniPilot electric proportional control system	—	—
MOUNTING		
Rear three point linkage	■	■
Rear four Point linkage	—	—
Rear subframe axle mounts	—	—
ARM TYPES		
Standard arm = S	■	■
Telescopic arm = T	—	—
Variable forward reach arm = VFR	—	—
Parallel arm system	—	—
HYDRAULIC SYSTEM		
System	Gear	Gear
Pump	Iron	Iron
Pump arrangement	Twin	Twin
Drive type	Fully Independent	Fully Independent
Tank capacity	190 litres (334 pints)	190 litres (334 pints)
Horsepower	60hp	60hp
Flow rate	90 l/min	90 l/min
KEY FEATURES & OPTIONS		
Hydraulic slew	■	■
Dual direction rotor (cable)	■	■
Hydraulic oil	■	■
Biodegradeable oil	□	□
Narrow lane bracket	—	—
Mechanical quick release kit (1 set - M/F)	□	□
Hydraulic quick release kit (1 set - M/F)	□	□
SAFETY EQUIPMENT		
Cab guard kit	■	■
Debris blower and mounting kit	—	—
Warning arrow kit	□	□
LED road lighting kit	□	□
Flashing LEDs	—	—

*Weights may vary dependent on machine type and specification

TWIGA CLASSIC SERIES

■ Standard Equipment □ Optional Equipment — Not available

FEATURES	S51	S55	VFR55	S60	VFR60	T65
SPECIFICATION						
Machine weight*	1200kg (2646lbs)	1230kg (2712lbs)	1320kg (2911lbs)	1250kg (2756lbs)	1340kg (2955lbs)	1310kg (2889lbs)
TRACTOR REQUIREMENTS						
Minimum tractor weight guide	4000kg (8820lbs)	4250kg (9371lbs)	4250kg (9371lbs)	4500kg (9923lbs)	4500kg (9923lbs)	4500kg (9923lbs)
TWIGA CONTROL SYSTEMS						
Pilot hydraulic proportional control system	■	■	■	■	■	■
MiniPilot electric proportional control system	□	□	□	□	□	□
MOUNTING						
Rear three point linkage	■	■	■	■	■	■
Rear four Point linkage	□	□	□	□	□	□
Rear subframe axle mounts	□	□	□	□	□	□
ARM TYPES						
Standard arm = S	■	■	—	■	—	—
Telescopic arm = T	—	—	—	—	—	■
Variable forward reach arm = VFR	—	—	■	—	■	—
Parallel arm system	■	■	■	■	■	■
HYDRAULIC SYSTEM						
System	Gear	Gear	Gear	Gear	Gear	Gear
Pump	Iron	Iron	Iron	Iron	Iron	Iron
Pump arrangement	Twin	Twin	Twin	Twin	Twin	Twin
Drive type	Fully Independent	Fully Independent	Fully Independent	Fully Independent	Fully Independent	Fully Independent
Tank capacity	190 litres (334 pints)	190 litres (334 pints)	190 litres (334 pints)	190 litres (334 pints)	190 litres (334 pints)	190 litres (334 pints)
Horsepower	65hp	65hp	65hp	65hp	65hp	65hp
Flow rate	90 l/min	90 l/min	90 l/min	90 l/min	90 l/min	90 l/min
KEY FEATURES & OPTIONS						
Cushioned top link	■	■	■	■	■	■
Hydraulic slew	■	■	■	■	■	■
Dual direction rotor (cable)	■	■	■	■	■	■
Autoreset	—	—	—	—	—	—
Head float	■	■	■	■	■	■
Arm float	□	□	□	□	□	□
Oil cooler	□	□	□	□	□	□
Hydraulic oil	■	■	■	■	■	■
Biodegradeable oil	□	□	□	□	□	□
Narrow lane bracket	□	□	□	□	□	□
Mechanical quick release kit (1 set - M/F)	□	□	□	□	□	□
Hydraulic quick release kit (1 set - M/F)	□	□	□	□	□	□
SAFETY EQUIPMENT						
Cab guard kit	■	■	■	■	■	■
Debris blower and mounting kit	□	□	□	□	□	□
Warning arrow kit	□	□	□	□	□	□
LED road lighting kit	■	■	■	■	■	■
Flashing LEDs	□	□	□	□	□	□



For full machine dimensions please scan the code or visit www.spearheadmachinery.com/dimensions



For full machine dimensions please scan the code or visit www.spearheadmachinery.com/dimensions

TWIGA MID SERIES

■ Standard Equipment □ Optional Equipment — Not available

FEATURES	S55	VFR55	S60	VFR60	T65	T70
SPECIFICATION						
Machine weight*	1400kg (3087lbs)	1510kg (3330lbs)	1420kg (3131lbs)	1530kg (374lbs)	1520kg (3352lbs)	1580kg (3484lbs)
TRACTOR REQUIREMENTS						
Minimum tractor weight guide	4250kg (9371lbs)	4500kg (9923lbs)	4500kg (9923lbs)	4750kg (10474lbs)	4750kg (10474lbs)	5000kg (11025lbs)
TWIGA CONTROL SYSTEMS						
Multipilot hydraulic proportional control system	■	■	■	■	■	■
Minipilot electric proportional control system	□	□	□	□	□	□
MOUNTING						
Rear three point linkage	■	■	■	■	■	■
Rear four point linkage	□	□	□	□	□	□
Rear subframe axle mounts	□	□	□	□	□	□
ARM TYPES						
Standard arm = S	■	—	■	—	—	—
Telescopic arm = T	—	—	—	—	■	■
Forward reach arm = Fr	—	—	—	—	—	—
Variable forward reach arm = VFR	—	■	—	■	—	—
Parallel arm system	■	■	■	■	■	■
HYDRAULIC SYSTEM						
System	Gear	Gear	Gear	Gear	Gear	Gear
Pump	Iron	Iron	Iron	Iron	Iron	Iron
Pump arrangement	Twin	Twin	Twin	Twin	Twin	Twin
Drive type	Fully Independent	Fully Independent	Fully Independent	Fully Independent	Fully Independent	Fully Independent
Tank capacity	210 litres (370 pints)	210 litres (370 pints)	210 litres (370 pints)	210 litres (370 pints)	210 litres (370 pints)	210 litres (370 pints)
Horsepower	75hp	75hp	75hp	75hp	75hp	75hp
Flow rate	105 l/min	105 l/min	105 l/min	105 l/min	105 l/min	105 l/min
KEY FEATURES & OPTIONS						
Cushioned top link	■	■	■	■	■	■
Hydraulic slew	■	■	■	■	■	■
Autoreset	■	■	■	■	■	■
Dual direction rotor (electric)	■	■	■	■	■	■
Head float	■	■	■	■	■	■
Arm float	□	□	□	□	□	□
Autopilot	□	□	□	□	□	□
Oil cooler	■	■	■	■	■	■
Hydraulic oil	■	■	■	■	■	■
Biodegradeable oil	□	□	□	□	□	□
Narrow lane bracket	□	□	□	□	□	□
Mechanical quick release kit (1 set - M/F)	□	□	□	□	□	□
Hydraulic quick release kit (1 set - M/F)	□	□	□	□	□	□
SAFETY EQUIPMENT						
Cab guard kit	■	■	■	■	■	■
Debris blower and mounting kit	□	□	□	□	□	□
Warning arrow kit	□	□	□	□	□	□
LED road lighting kit	■	■	■	■	■	■
Flashing LEDs	□	□	□	□	□	□

*Weights may vary dependent on machine type and specification

TWIGA ORBITAL SERIES

■ Standard Equipment □ Optional Equipment — Not available

FEATURES	S60	S67	T72	T83
SPECIFICATION				
Machine weight*	1900kg (4190lbs)	2050kg (4520lbs)	2120kg (4678lbs)	2290kg (2290lbs)
TRACTOR REQUIREMENTS				
Minimum tractor weight guide	4750kg (10474lbs)	5000kg (11025lbs)	5250kg (11576lbs)	5500kg (12128lbs)
TWIGA CONTROL SYSTEMS				
Multipilot hydraulic proportional control system	■	■	■	■
Propilot	□	□	□	□
MOUNTING				
Rear three point linkage	■	■	■	■
Rear four point linkage	□	□	□	□
Rear subframe axle mounts	□	□	□	□
ARM TYPES				
Standard arm = S	■	■	—	—
Telescopic arm = T	—	—	■	■
Parallel arm system	■	■	■	■
HYDRAULIC SYSTEM				
System	Gear	Gear	Gear	Gear
Pump	Iron	Iron	Iron	Iron
Pump arrangement	Twin	Twin	Twin	Twin
Drive type	Fully Independent	Fully Independent	Fully Independent	Fully Independent
Tank capacity	200 litres (352 pints)	200 litres (352 pints)	200 litres (352 pints)	200 litres (352 pints)
Horsepower	80hp	80hp	80hp	80hp
Flow rate	105 l/min	105 l/min	105 l/min	105 l/min
KEY FEATURES & OPTIONS				
Cushioned top link	■	■	■	■
Hydraulic slew	■	■	■	■
Dual direction autoreset	■	■	■	■
Dual direction rotor (Electric)	■	■	■	■
Head float	■	■	■	■
Arm float	□	□	□	□
Autopilot	□	□	□	□
Autoflex	□	□	□	□
Oil cooler	■	■	■	■
Hydraulic oil	■	■	■	■
Biodegradeable oil	□	□	□	□
Narrow lane bracket	□	□	□	□
Mechanical quick release kit (1 set - M/F)	□	□	□	□
Hydraulic quick release kit (1 set - M/F)	□	□	□	□
1000rpm	□	□	□	□
SAFETY EQUIPMENT				
Cab guard kit	■	■	■	■
Debris blower and mounting kit	□	□	□	□
Warning arrow kit	□	□	□	□
LED road lighting kit	■	■	■	■
Boom light	□	□	□	□

*Weights may vary dependent on machine type and specification



For full machine dimensions please scan the code or visit www.spearheadmachinery.com/dimensions



For full machine dimensions please scan the code or visit www.spearheadmachinery.com/dimensions

TWIGA PRO SERIES

■ Standard Equipment □ Optional Equipment — Not available

FEATURES	VFR60	VFR65	T70	VFRT72	T80
SPECIFICATION					
Machine weight*	1720kg (3793lbs)	1800kg (3969lbs)	1870kg (4123lbs)	2000kg (4410lbs)	1930kg (4256lbs)
TRACTOR REQUIREMENTS					
Minimum tractor weight guide	5000kg (11025lbs)	5000kg (11025lbs)	5000kg (11025lbs)	5250kg (11576lbs)	5250kg (11576lbs)
TWIGA CONTROL SYSTEMS					
Propilot control system	■	■	■	■	■
MOUNTING					
Rear three point linkage	■	■	■	■	■
Rear three point linkage with four point kit	□	□	□	□	□
Rear subframe axle mounts	□	□	□	□	□
Rear integrated axle mounts	□	□	□	□	□
ARM TYPES					
Standard arm = S	■	—	■	—	—
Telescopic arm = T	—	—	—	—	■
Variable forward reach arm = VFR	—	■	—	■	—
Parallel arm system	■	■	■	■	■
HYDRAULIC SYSTEM					
System	Gear	Gear	Gear	Gear	Gear
Pump	Iron	Iron	Iron	Iron	Iron
Pump arrangement	Twin	Twin	Twin	Twin	Twin
Drive type	Fully Independent	Fully Independent	Fully Independent	Fully Independent	Fully Independent
Tank capacity	200 litres (352 pints)	200 litres (352 pints)	200 litres (352 pints)	200 litres (352 pints)	200 litres (352 pints)
Horsepower	85hp	85hp	85hp	85hp	85hp
Flow rate	110 l/min	110 l/min	110 l/min	110 l/min	110 l/min
KEY FEATURES & OPTIONS					
Cushioned top link	■	■	■	■	■
Hydraulic slew	■	■	■	■	■
Autoreset	■	■	■	■	■
Dual direction rotor (electric)	■	■	■	■	■
Head float	■	■	■	■	■
Autopilot	■	■	■	■	■
Oil cooler	■	■	■	■	■
Hydraulic oil	■	■	■	■	■
Biodegradeable oil	□	□	□	□	□
Narrow lane bracket	□	□	□	□	□
Mechanical quick release kit (1 set - M/F)	□	□	□	□	□
Hydraulic quick release kit (1 set - M/F)	□	□	□	□	□
Counterweight	□	□	□	□	□
1000rpm	□	□	□	□	□
SAFETY EQUIPMENT					
Cab guard kit	■	■	■	■	■
Debris blower	□	□	□	□	□
Warning arrow kit	□	□	□	□	□
LED road Lighting kit	■	■	■	■	■
Flashing LEDs	□	□	□	□	□

*Weights may vary dependent on machine type and specification

TWIGA FLEX SERIES

■ Standard Equipment □ Optional Equipment — Not available

FEATURES	S67	S74	T80	T89
SPECIFICATION				
Machine weight*	2050kg (4520lbs)	2170kg (4785lbs)	2380kg (5248lbs)	2600kg (5733lbs)
TRACTOR REQUIREMENTS				
Minimum tractor weight guide	5500kg (12128lbs)	5500kg (12128lbs)	5750kg (12679lbs)	6000kg (13230lbs)
TWIGA CONTROL SYSTEMS				
Propilot	■	■	■	■
Propilot+	□	□	□	□
MOUNTING				
Rear three point linkage	■	■	■	■
Rear three point linkage with four point kit	□	□	□	□
Rear subframe axle mounts	□	□	□	□
Rear integrated axle mounts	□	□	□	□
Front three point linkage	□	□	□	□
Front DIN mounts	□	□	□	□
ARM TYPES				
Standard arm = S	■	■	—	—
Telescopic arm = T	—	—	■	■
Parallel arm system	■	■	■	■
HYDRAULIC SYSTEM				
System	Gear	Gear	Gear	Gear
Pump	Iron	Iron	Iron	Iron
Pump arrangement	Twin	Twin	Twin	Twin
Drive type	Fully Independent	Fully Independent	Fully Independent	Fully Independent
Tank capacity	200 litres (352 pints)	200 litres (352 pints)	200 litres (352 pints)	200 litres (352 pints)
Horsepower	85hp	85hp	85hp	85hp
Flow rate	110 l/min	110 l/min	110 l/min	110 l/min
KEY FEATURES & OPTIONS				
Cushioned top link	■	■	■	■
Hydraulic Slew	■	■	■	■
Dual direction break back	■	■	■	■
Dual direction rotor (electric)	■	■	■	■
Head float	■	■	■	■
Autopilot	■	■	■	■
Autoflex	■	■	■	■
Oil cooler	■	■	■	■
Hydraulic oil	■	■	■	■
Biodegradeable oil	□	□	□	□
Mechanical quick release kit (1 set - M/F)	□	□	□	□
Hydraulic quick release kit (1 set - M/F)	□	□	□	□
Counterweight	□	□	□	□
1000rpm	□	□	□	□
SAFETY EQUIPMENT				
Cab guard kit	■	■	■	■
Debris blower	□	□	□	□
Warning arrow kit	□	□	□	□
LED road lighting kKit	■	■	■	■
Boom light	□	□	□	□

*Weights may vary dependent on machine type and specification



For full machine dimensions please scan the code or visit www.spearheadmachinery.com/dimensions



For full machine dimensions please scan the code or visit www.spearheadmachinery.com/dimensions

SPEARHEAD

Station Road, Salford Priors, Evesham, Worcestershire, WR11 8SW, England

+44 (0)1789 491860 ✉ enquiries@spearheadmachinery.com fX [SpearheadWorld](#)

spearheadmachinery.com

 A Member of the **ALAMO GROUP**

All information in this brochure is correct at the time of printing. Spearhead Machinery Limited reserves the right to change any of the data or descriptions at any time without prior warning. All dimensions are for reference.