

TWIGA 600

- Cable Controls
- Three Point Linkage Mounting
- Left Hand or Right Hand Build Option
- Cushion Top Link
- LED Rear Lighting Kit
- Parallel Arm Geometry
- Totally Independent 66HP Hydraulic System
- Cast Iron Pumps and Motor
- Heavy Duty Cast Iron Gearbox
- Hydraulic Slew and Safety Breakaway
- 220 Litre Oil Capacity
- 1.2 Metre MP2 Flailhead

Optional Extras

- Precision Proportional Control
- Propilot Controls
- Electric Rotor Control - Dual Rotation (Propilot Only)
- Head Float Kit (Standard on Propilot Builds)
- Arm Float Kit
- Autopilot
- Oil Cooler Kit
- Axle Mounting System
- Forward Reach Kit
- Narrow Lane Bracket
- Debris Blower Kit
- Hydraulic Oil
- Belt Drive Flailhead

MODEL	TWIGA 600
Maximum reach	6.0m
Machine weight*	1380kg
Oil tank capacity	220ltr
Transport width	2.6m
Gear totally independent hydraulics	STD
3-point linkage mounting	STD
Axle mounting	Option
Right hand or left hand build	Option
LED lighting kit	STD
Tractor power required**	95hp
Tractor weight required**	3750kg

*Dependant on machine specification (including oil, excluding flailhead or attachment)
 **Dependant on conditions

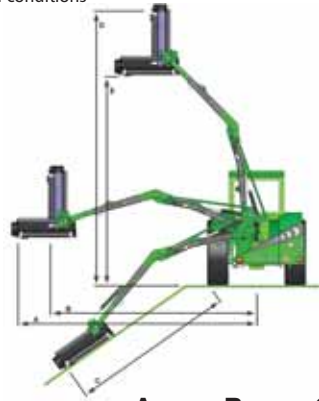

	A	B	C	D	E
TWIGA 600	6.0m	5.3m	4.2m	6.7m	5.2m

